

INCONTESTABLE !

Lighting



- Bulb is integrated in the front flange, thus spreading the illumination evenly over dome and card and preventing eye strain and fatigue at night.
- Easy access to the light bulb from the front of the compass.

Contest 101 compass

Watertight construction



- One-piece moulded flange and front dome.
- Vitor® diaphragm with extreme expansion and retraction capacity, compensates the fluctuations in fluid volume caused by the differences in temperature and atmospheric pressure, thus preventing the formation of bubbles.

Materials

- All parts fully UV-ray treated
- Scratch resistant dome.

3 lubber lines

For dependable readings even when steering windward.



Anti-theft design

Thanks to moulded-in sunken head screws.



Assembly is easily waterproof

- Exclusive installation design allows the compass to fit any bulkhead, vertical or inclined up to 25° from tilt, either by screwing from the cockpit side
- or by screwing from the cabin side as an anti-theft security.
- This very bulkhead thickness:
- Bulkhead of standard thickness (up to 40 mm) : the compass is secured with threaded rods.
- Thick or double bulkhead : the compass is secured with screws on both sides of the bulkhead.
- Supplied with back flange for neat installation from cabin side.

Double reading

From both cockpit and cabin.



Compensation

Easy access to compensation box from the front of the compass.



Simply swap them without any new hole, and without any tooling. The Contest 101 has the same mounting footprint as the Contest 100.

Contest® 130

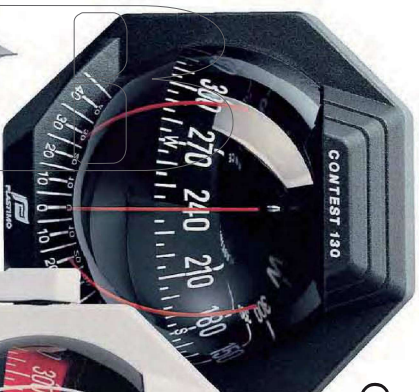

Contest® 130

The perfect card stability and exceptional magnification of the Contest 130 give the user an unparalleled quality of reading by day or by night. The Contest 130 remains perfectly legible from a 5 m distance.

CONTEST 130

Boat size 9 metres and above (30 ft +)

Compass Double graduation : horizontal and vertical, apparent Ø 127 mm, Heading numerals every 30°.

Mounting • Bulkhead (vertical or 10°-25° inclined bulkhead).
• On a bracket.

Lubber lines Δ lubber lines, at 45°.

Heelmeter Graduated every 10°.

Compensation Included as standard.

Lighting 12 Vdc double lighting (upper and lower), Red lighting on black card, white lighting on red card.

Supplied with Protection cover, drilling template.

Homologation SOLAS MED 96-98.

CONTEST 130	Bulkhead-mount vertical	Bracket-mount vertical
• BLACK COMPASS	39649	40034
black card	17291	17292
• WHITE COMPASS	17294	17295
red card	-	-

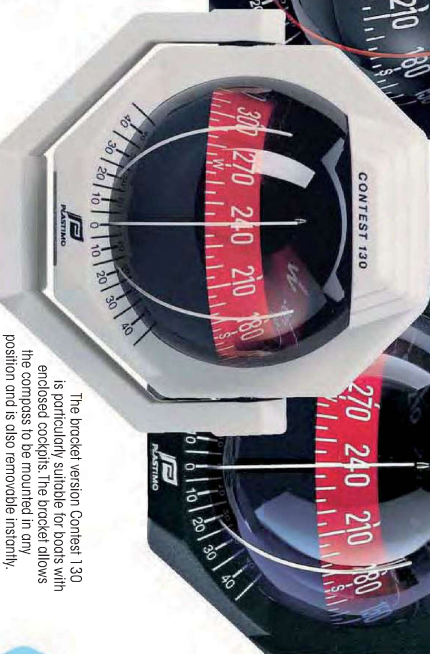

The bracket version Contest 130 is particularly suitable for boats with enclosed cockpits. The bracket allows the compass to be mounted in any position and is also removable instantly.

The model for inclined bulkhead is designed for a bulkhead fitted by 10° to 25° from vertical. The card remains fully efficient, even with a very high angle of pitch.

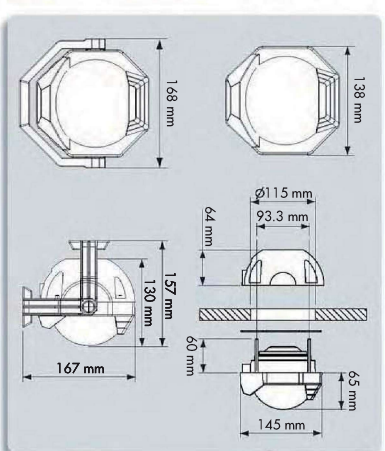

Options & accessories



• Most mounting kit : 39216

• Spare protection cover : 17296