

SPECIFICATIONS OF GP-33

DISPLAY

Screen Size 4.3" color LCD
 Effective Display Area 95.04 (W) x 53.85 (H) mm
 Pixel Number 480 (V) x 272 (H) pixels

Display Mode

Plotter, Highway, Steering, Nav Data, Satellite, User Display1, User Display2

Memory Capacity

3,000 ship's track points
 10,000 marks and waypoints with comments
 100 routes, 30 waypoints/route

Alarm

Arrival, Anchor watch, XTE, Speed, WAAS, Time, Trip, Odometer

GPS/WAAS

Receiver Type

GPS: Twelve discrete channels, C/A code, all-in-view
 WAAS receiver: Standard fitted in display unit

Receive Frequency L1 (1575.42 MHz)

Time to First Fix Less than 90 seconds (Cold start)

Tracking Velocity 999.9 knots

Geodetic Systems WGS-84 (and others)

ACCURACY

GPS: Better than 10 m (2drms)

WAAS: Better than 3 m (2drms)

INTERFACE

Ports

CAN bus: 1 port
 NMEA0183: 2 ports

Display Unit GP-33

0.72 kg 1.58 lb

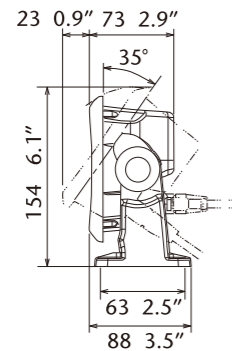
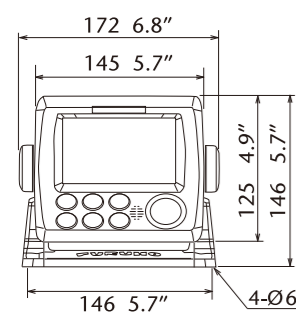

Flush mount
 0.61 kg 1.34 lb

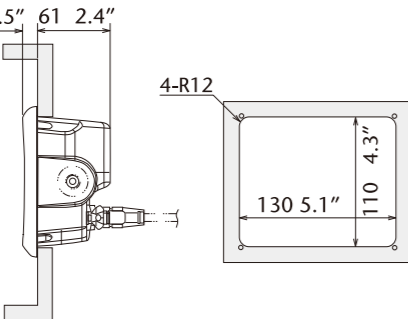
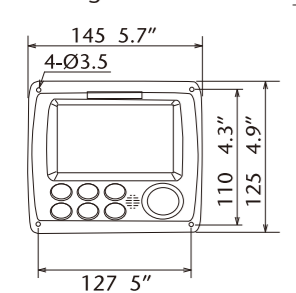

GPS Antenna GPA-017

0.6 kg 1.3 lb

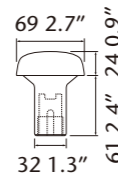

Output

NMEA0183

AAM, APB, BOD, BWC, BWR, DTM, GGA, GLL, GSA, GSV, RMB, RMC, VTC, XTE, ZDA

CAN bus

059392, 060928, 061184, 126208, 126464, 126720-1, 126720-2, 126992, 126996, 127258, 129026, 129029, 129033, 129044, 129283, 129284, 129285, 129538, 129539, 129540, 130822, 130823

Input

CAN bus

059904, 060928, 061184, 065286, 126208, 126720

POWER SUPPLY

15 VDC : LEN7 (CAN bus)
 12-24 VDC : 0.24-0.12 A (Non CAN bus)

ENVIRONMENT

Temperature

Receiver unit: -15°C to +55°C
 Antenna unit: -25°C to +70°C

Waterproofing

Receiver unit: IP56
 Antenna unit: IPX6

EQUIPMENT LIST

Standard

1. Receiver unit GP-33 with drop cable 6 m 1 unit
2. Antenna unit GPA-017 with cable 10 m 1 unit
3. Standard spare parts and installation materials

Option

1. Junction box FI-5002
2. Cable assembly KON-004-02M (NMEA0183) 2 m

OFFICIAL NAME OF THE EQUIPMENT

GPS Navigator GP-33

INTERCONNECTION DIAGRAM

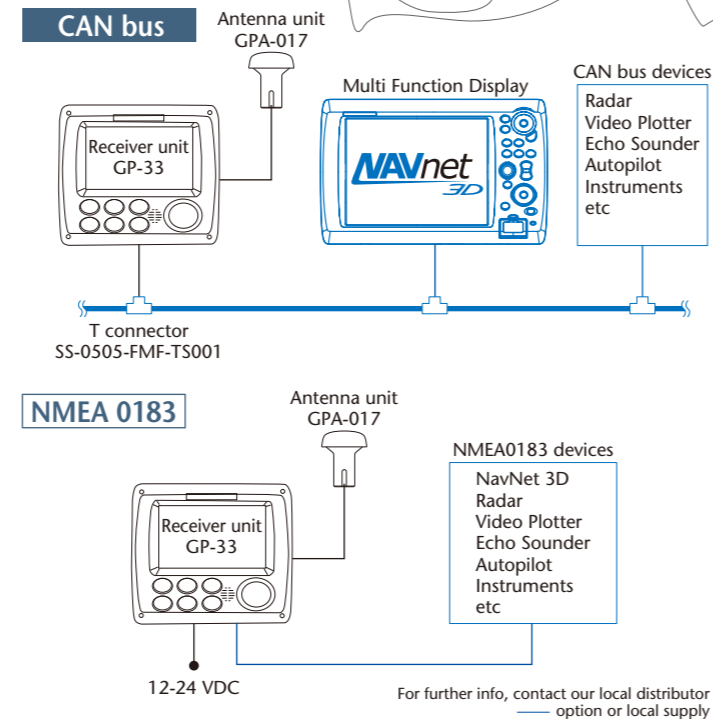

SPECIFICATIONS SUBJECT TO CHANGE WITHOUT NOTICE

All brand and product names are registered trademarks, trademarks or service marks of their respective holders



FURUNO

GP-33

GPS NAVIGATOR



FURUNO ELECTRIC CO., LTD.
 Nishinomiya, Hyogo, Japan
 www.furuno.co.jp

FURUNO U.S.A., INC.
 Camas, Washington, U.S.A.
 www.furunousa.com

FURUNO (UK) LIMITED
 Havant, Hampshire, U.K.
 www.furuno.co.uk

FURUNO FRANCE S.A.S.
 Bordeaux-Mérignac, France
 www.furuno.fr

FURUNO ESPAÑA S.A.
 Madrid, Spain
 www.furuno.es

FURUNO DANMARK AS
 Hvidovre, Denmark
 www.furuno.dk

FURUNO NORGE A/S
 Ålesund, Norway
 www.furuno.no

FURUNO SVERIGE AB
 Västra Frölunda, Sweden
 www.furuno.se

FURUNO FINLAND OY
 Espoo, Finland
 www.furuno.fi

FURUNO POLSKA Sp. z o.o.
 Gdynia, Poland
 www.furuno.pl

FURUNO EURUS LLC
 St. Petersburg, Russian Federation
 www.furuno.com.ru

FURUNO DEUTSCHLAND GmbH
 Pellingen, Germany
 www.furuno.de

FURUNO HELLAS S.A.
 Piraeus, Greece

RICO (PTE) LTD
 Singapore
 www.rico.com.sg

1103-pdf
 Catalogue No. N-871b



www.furuno.com

A smart navigation solution that fits perfect into your console

Compact in size, yet big on features and performance, the FURUNO GP-33 is the perfect GPS navigator for a wide range of vessels. This advanced unit provides accurate and reliable position fixing, thanks to a super sensitive, 12-channel GPS receiver combined with integrated WAAS technology.

The GP-33 has a waterproof display and is built to stand up to tough marine conditions. The durable casing houses an impressive memory, capable of storing up to 3,000 points of ship's track, 10,000 points for marks and waypoints, and 100 routes of up to 30 waypoints each. Vital navigation data is presented on a 4.3" color LCD.

The GP-33 features FURUNO's CAN bus interface system for feeding highly accurate navigation data to your NavNet 3D, radar, chart plotter, autopilot, fish finder or other navigation equipment. The unit offers easy plug-and-play installation with CAN bus network connectivity. NMEA0183 protocol versions are also supported.

- ▶ 4.3" "Sunlight Viewable" color LCD (Brightness: 700 cd)
- ▶ Enhanced data legibility thanks to large characters and high resolution visual aid
- ▶ Stores up to 10,000 marks/waypoints, 100 routes and 3,000 track points
- ▶ 7 display modes available, including 2 user-customized modes
- ▶ Supports both NMEA0183 and CAN bus interface
- ▶ Contact closure capability available on the 10P connector
- ▶ SBAS capable for better measurement

SBAS is a general term for a GPS navigation system with differential correction by means of geostationary satellites. In the US, it is called WAAS (Wide Area Augmentation System), whereas in Europe and Japan, it is called EGNOS (European Geostationary Navigation Overlay System) and MSAS (MSAT Satellite-based Augmentation System), respectively.

Various Displays

The GP-33 provides navigation data and displays them in a wide variety of numerical and graphical formats. You may freely select which data you want displayed with easy to use controls. The combination of a high resolution screen and large data fields makes the screen easy to read in almost any condition.

NAV data



The nav data display shows receiver status, position in latitude and longitude (or TDs), course over ground, speed over ground, date and time.

COG



Easy to read digital compass heading display that greatly assists you in maintaining a desired course.

Highway

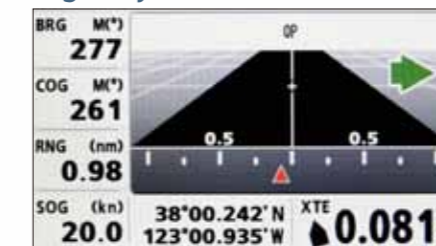

3-D view of own ship's progress toward destination (waypoint). This mode is best used for navigation when a straight line course can be followed.

User Display



You choose what data is displayed in the User Display Mode.

Plotter

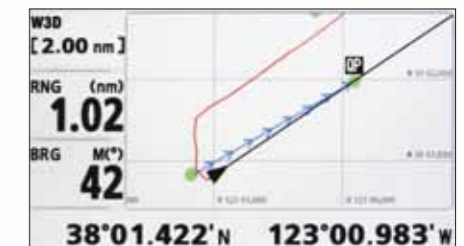

The plotter display traces own ship's track and shows position on a 2-D map*. This mode presents various data and information with graphic symbols and icons, rather than text. The Auto Waypoint Entry function plots ship's track as "WAYPOINTS". The user may define waypoint entry by time interval, tack angle, etc.

*The unit does not include charts.



What is CAN bus?

CAN bus is a communication protocol that shares multiple data and signals through a single backbone cable. You can simply connect any CAN bus devices onto the backbone cable to expand your network onboard. With CAN bus, IDs are assigned to all the devices, and the status of each sensor in the network can be detected. All the CAN bus devices can be incorporated into the NMEA2000 network.



Easy Operation

Innovative digital graphic displays and intuitive on-screen menu structure provide simple operation and easy access to the features you use most frequently.



GP-33 GPS NAVIGATOR

