

# HD / SHD Digital Open Array radar

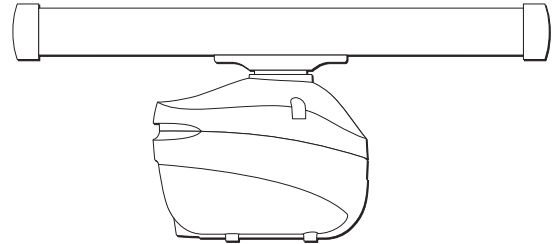

SVB

Installation instructions

**ENGLISH**

Date: 12-2009

Document number: 87087-5

© 2009 Raymarine UK Limited

INNOVATION • QUALITY • TRUST

**Raymarine®**

SVIB

## **Trademarks and registered trademarks**

Autohelm, HSB, RayTech Navigator, Sail Pilot, SeaTalk and Sportpilot are UK registered trademarks of Raymarine UK Limited. Pathfinder and Raymarine are UK registered trademarks of Raymarine Holdings Limited. 33STV, 45STV, 60STV, AST, Autoadapt, Auto GST, AutoSeastate, AutoTrim, Bidata, G Series, HDFI, LifeTag, Marine Intelligence, Maxiview, On Board, Raychart, Raynav, Raypilot, RayTalk, Raystar, ST40, ST60+, Seaclutter, Smart Route, Tridata, UniControl, Hybridtouch, and Waypoint Navigation are trademarks of Raymarine UK Limited.

All other product names are trademarks or registered trademarks of their respective owners.

## **Fair Use Statement**

You may print no more than three copies of this manual for your own use. You may not make any further copies or distribute or use the manual in any other way including without limitation exploiting the manual commercially or giving or selling copies to third parties.

**Copyright ©2009 Raymarine UK Ltd. All rights reserved.**

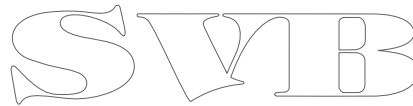

## **ENGLISH**

Document number: 87087-5

Date: 12-2009

SVIB

# Contents

<b>Chapter 1 Important information.....</b>	<b>7</b>	3.4 Radar scanner power connections .....	21
Certified Installation .....	7	3.5 Radar scanner data connections .....	22
Transmitted power density levels .....	7	3.6 Digital radar cable extension .....	23
Water ingress .....	8	3.7 Digital radar cables .....	24
EMC installation guidelines .....	8	3.8 VCM100 power connections .....	25
Suppression ferrites .....	8	3.9 VCM100 power cable extension .....	27
Declaration of conformity .....	8	3.10 VCM100 screen (drain) wire extension .....	27
Product disposal .....	9	3.11 Circuit breaker and fuse ratings .....	28
Warranty registration .....	9	3.12 Sharing a breaker .....	28
IMO and SOLAS .....	9	<b>Chapter 4 Location and mounting .....</b>	<b>29</b>
Technical accuracy .....	9	4.1 Selecting a location .....	30
Multifunction display software version .....	9	4.2 Mounting .....	34
<b>Chapter 2 Planning the installation .....</b>	<b>11</b>	<b>Chapter 5 System checks .....</b>	<b>41</b>
2.1 Handbook information .....	12	5.1 Radar scanner initial power on test .....	42
2.2 Installation checklist .....	12	5.2 Radar check .....	42
2.3 Typical system examples .....	13	<b>Chapter 6 Troubleshooting .....</b>	<b>45</b>
2.4 Pack contents .....	15	6.1 Troubleshooting .....	46
2.5 Tools .....	16	6.2 Power up troubleshooting .....	47
<b>Chapter 3 Cables and connections .....</b>	<b>17</b>	6.3 Radar troubleshooting .....	48
3.1 General cabling guidance .....	18	6.4 System data troubleshooting .....	49
3.2 Radar scanner connection .....	19	6.5 VCM100 LED indications .....	50
3.3 Product grounding .....	19	6.6 SeaTalk <sup>hs</sup> LED indications .....	50



**Chapter 7 Technical support ..... 51**

7.1 Raymarine technical support..... 52

**Chapter 8 Technical specification..... 53**

8.1 Technical specification..... 54

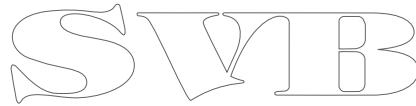

# Chapter 1: Important information

## Certified Installation

Raymarine recommends certified installation by a Raymarine approved installer. A certified installation qualifies for enhanced product warranty benefits. Contact your Raymarine dealer for further details, and refer to the separate warranty document packed with your product.



### Warning: Product installation and operation

This product must be installed and operated in accordance with the Raymarine instructions provided. Failure to do so could result in personal injury, damage to your boat and/or poor product performance.



### Warning: High voltages

This product contains high voltages. Do NOT remove any covers or otherwise attempt to access internal components, unless specifically instructed in this document.



### Warning: Product grounding

Before applying power to this product, ensure it has been correctly grounded, in accordance with the instructions in this guide.



### Warning: Switch off power supply

Ensure the boat's power supply is switched OFF before starting to install this product. Do NOT connect or disconnect equipment with the power switched on, unless instructed in this document.



### Warning: Radar scanner safety

Before rotating the radar scanner, ensure all personnel are clear.



### Warning: Radio frequency radiation hazard

The radar scanner transmits electromagnetic energy at microwave frequencies which can be harmful, particularly to the eyes. Do NOT look at the scanner from close range. Ensure personnel are clear of the scanner when it is powered on.

For safety reasons, the radar must be installed above head height, out of range of personnel.

## Transmitted power density levels

- A power density level of 10 W/m<sup>2</sup> is likely at distances of 34 cm or less from the radar scanner.
- A power density level of 100 W/m<sup>2</sup> does not occur at any point.

# Water ingress

## Water ingress disclaimer

Although the waterproof rating capacity of Raymarine products exceeds that called for by the IPX6 standard, water intrusion and subsequent equipment failure may occur if any Raymarine equipment is subjected to commercial high pressure washing. Raymarine will not warrant equipment subjected to high pressure washing.

# EMC installation guidelines

Raymarine equipment and accessories conform to the appropriate Electromagnetic Compatibility (EMC) regulations, to minimize electromagnetic interference between equipment and minimize the effect such interference could have on the performance of your system

Correct installation is required to ensure that EMC performance is not compromised.

For **optimum** EMC performance we recommend that wherever possible:

- Raymarine equipment and cables connected to it are:
  - At least 1 m (3 ft) from any equipment transmitting or cables carrying radio signals e.g. VHF radios, cables and antennas. In the case of SSB radios, the distance should be increased to 7 ft (2 m).
  - More than 2 m (7 ft) from the path of a radar beam. A radar beam can normally be assumed to spread 20 degrees above and below the radiating element.
- The product is supplied from a separate battery from that used for engine start. This is important to prevent erratic behavior

and data loss which can occur if the engine start does not have a separate battery.

- Raymarine specified cables are used.
- Cables are not cut or extended, unless doing so is detailed in the installation manual.

**Note: Where constraints on the installation prevent any of the above recommendations**, always ensure the maximum possible separation between different items of electrical equipment, to provide the best conditions for EMC performance throughout the installation

# Suppression ferrites

Raymarine cables may be fitted with suppression ferrites. These are important for correct EMC performance. If a ferrite has to be removed for any purpose (e.g. installation or maintenance), it must be replaced in the original position before the product is used.

Use only ferrites of the correct type, supplied by Raymarine authorized dealers.

# Declaration of conformity

Raymarine Ltd. declares that the HD and SuperHD Digital Open Array radar scanners are in compliance with the essential requirements of R & TTE directive 1999/5/EC.

The original Declaration of Conformity certificate may be viewed on the relevant product page at [www.raymarine.com](http://www.raymarine.com)



## Product disposal

Dispose of this product in accordance with the WEEE Directive.



■ The Waste Electrical and Electronic Equipment (WEEE) Directive requires the recycling of waste electrical and electronic equipment. Whilst the WEEE Directive does not apply to some Raymarine products, we support its policy and ask you to be aware of how to dispose of this product.

## Warranty registration

To register your HD and SuperHD Digital Open Array radar scanner ownership, please take a few minutes to fill out the warranty registration card found in the box, or visit [www.raymarine.com](http://www.raymarine.com) and register on-line.

It is important that you register your product to receive full warranty benefits. Your unit package includes a bar code label indicating the serial number of the unit. You should stick this label to the warranty registration card.

## IMO and SOLAS

The equipment described within this document is intended for use on leisure marine boats and workboats not covered by International Maritime Organization (IMO) and Safety of Life at Sea (SOLAS) Carriage Regulations.

## Technical accuracy

To the best of our knowledge, the information in this document was correct at the time it was produced. However, Raymarine cannot accept liability for any inaccuracies or omissions it may contain. In addition, our policy of continuous product improvement may change specifications without notice. As a result, Raymarine cannot accept liability for any differences between the product and this document.

## Multifunction display software version

To ensure optimum performance and compatibility with external devices, your multifunction display must be using the latest software version.

Visit [www.raymarine.com](http://www.raymarine.com) to download the latest software.

## Viewing multifunction display software information

1. Press the **MENU** button.
2. Select **System Diagnostics**.
3. Select **Software Services**.
4. Select **Unit Info**.

A range of information is displayed, including the App Version (software version).

## Radar scanner feature compatibility

The following table lists the features supported by the Digital Open Array radar scanner variants.

Feature	All HD variants	All SuperHD variants
Gain presets:		
— Buoy	✓	✓
— Harbor	✓	✓
— Coastal	✓	✓
— Offshore	✓	✓
— Bird Mode	✗	✓
Antenna Boost	✗	✓
Power Boost	✗	✓
Enhance echoes:		
— Interference Rejection	✓	✓
— Expansion	✓	✓
— Wakes	✓	✓

Feature	All HD variants	All SuperHD variants
Dual Range	✓	✓
Scanner rotation speed:		
24 RPM	✓	✓
48 RPM	✗	✓

STVIB

# Chapter 2: Planning the installation

## Chapter contents

- [2.1 Handbook information on page 12](#)
- [2.2 Installation checklist on page 12](#)
- [2.3 Typical system examples on page 13](#)
- [2.4 Pack contents on page 15](#)
- [2.5 Tools on page 16](#)

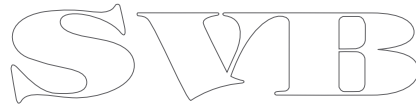

## 2.1 Handbook information

This handbook contains important information regarding the HD and SuperHD Digital Open Array range of radar scanners.

The handbook is for use with the following models:

- 48" and 72" 4kW HD Digital Open Array.
- 48" and 72" 12kW HD Digital Open Array.
- 48" and 72" 4kW SuperHD Digital Open Array.
- 48" and 72" 12kW SuperHD Digital Open Array.

### Further information

For detailed operating instructions, refer to the handbook that accompanies your multifunction display.

## 2.2 Installation checklist

Installation includes the following activities:

Installation Task	
1	Plan your system
2	Obtain all required equipment and tools
3	Site all equipment
4	Route all cables.
5	Drill cable and mounting holes.
6	Make all connections into equipment.
7	Secure all equipment in place.
8	Power on, test the system.

SVM3

## 2.3 Typical system examples

The Digital Open Array radar scanner can be connected to a variety of equipment as part of your marine electronics system.

### Radar connected using SeaTalk<sup>hs</sup> switch

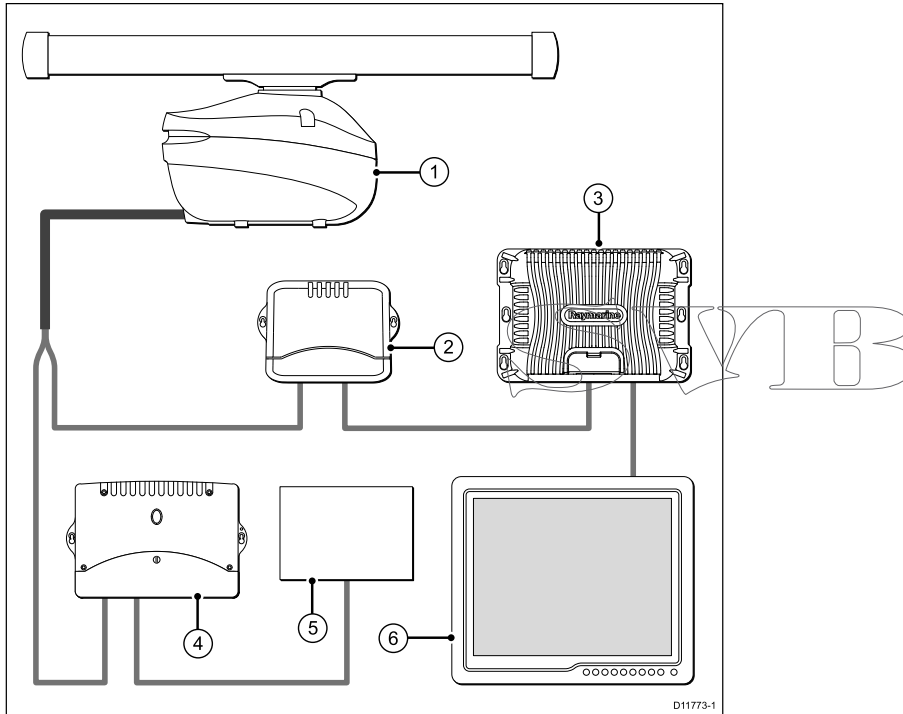

1. Digital Open Array radar scanner
2. SeaTalk<sup>hs</sup> switch

3. GPM400 G-Series processor
4. VCM100 power converter
5. Power supply
6. G-Series display

## Radar connected directly to multifunction display

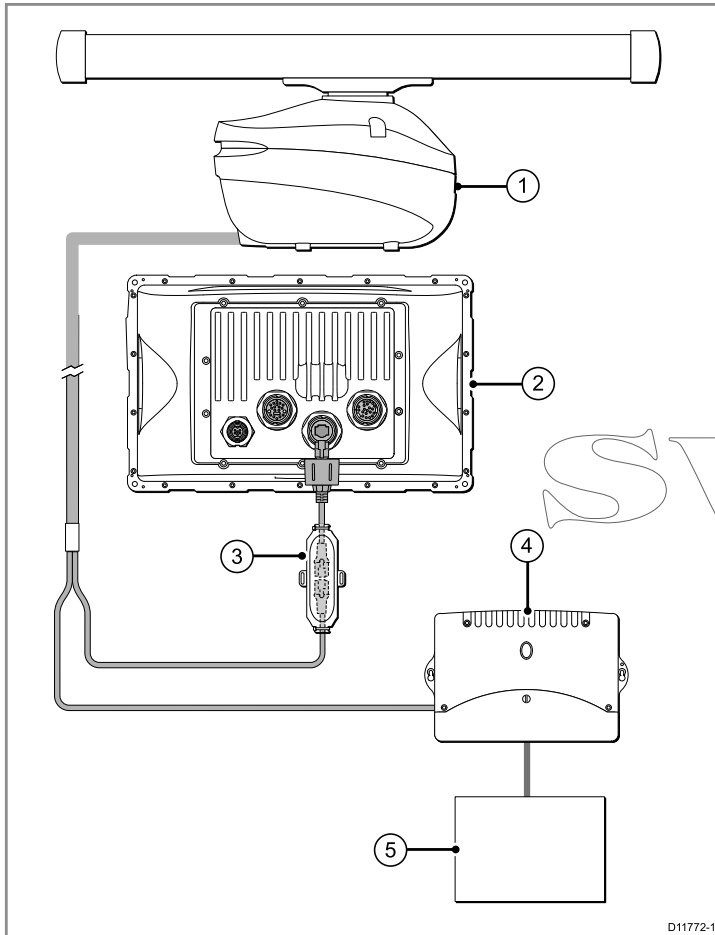

D11772-1

1. Digital Open Array radar scanner
2. Multifunction display
3. Crossover coupler
4. VCM100 power converter
5. Power supply

SVIB

## 2.4 Pack contents

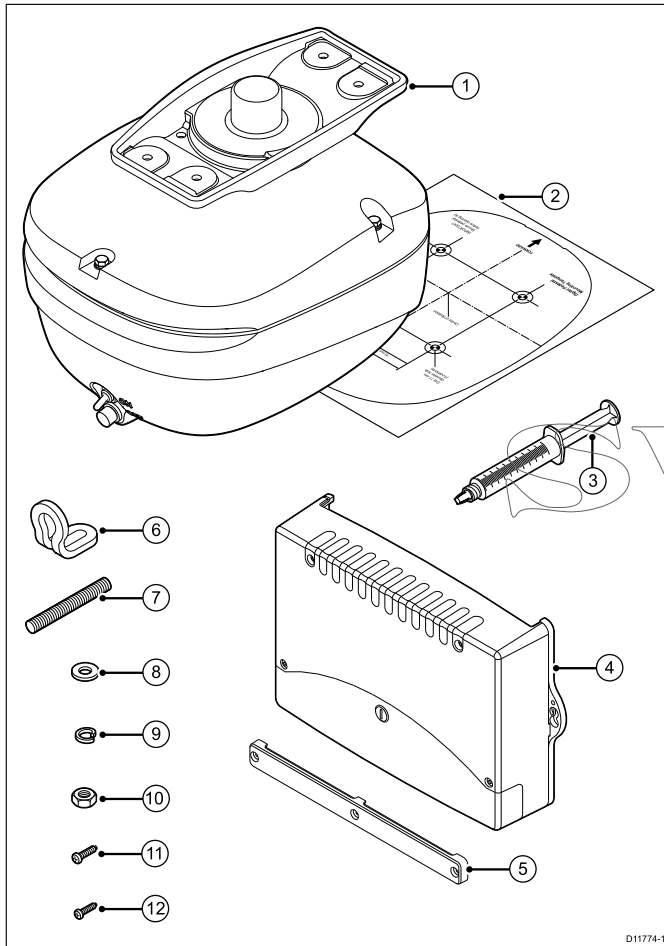

Item	Description	Quantity
1	Pedestal	1
2	Mounting template	1
3	Denso paste	1
4	VCM100 Voltage Converter Module	1
5	VCM100 cable clamp	1
6	Lifting eye	3
7	Stud	4
8	Plain washer	4
9	Spring washer	4
10	Nut	8
11	VCM100 mounting screw	2
12	VCM100 cable clamp mounting screw	3

## 2.5 Tools

Tools required for installation

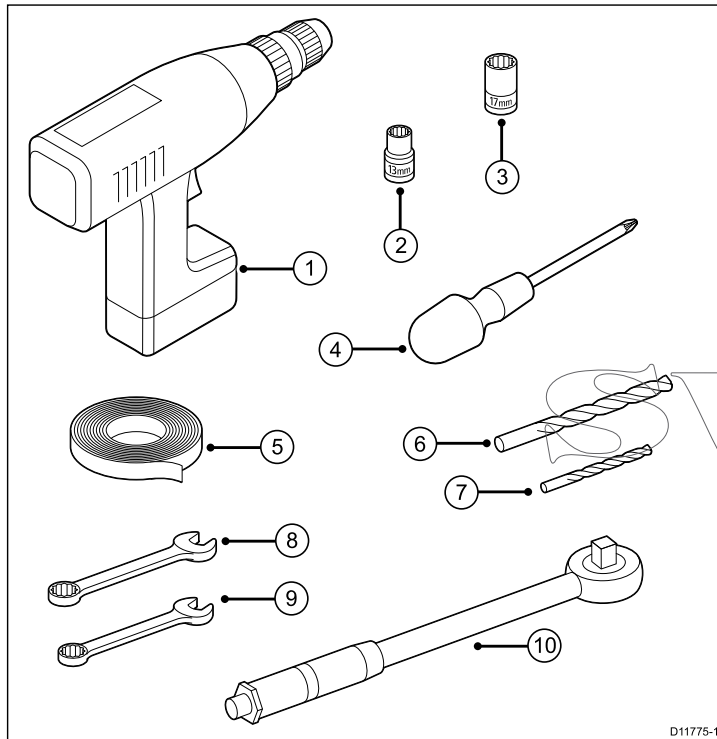

D11775-1

Item	Description
1	Power drill
2	13 mm socket
3	17 mm socket
4	Screwdriver ("Pozidrive" head)
5	Adhesive tape
6	11 mm drill bit
7	3 mm drill bit
8	17 mm spanner
9	13 mm spanner
10	Torque wrench



# Chapter 3: Cables and connections

## Chapter contents

- 3.1 General cabling guidance on page 18
- 3.2 Radar scanner connection on page 19
- 3.3 Product grounding on page 19
- 3.4 Radar scanner power connections on page 21
- 3.5 Radar scanner data connections on page 22
- 3.6 Digital radar cable extension on page 23
- 3.7 Digital radar cables on page 24
- 3.8 VCM100 power connections on page 25
- 3.9 VCM100 power cable extension on page 27
- 3.10 VCM100 screen (drain) wire extension on page 27
- 3.11 Circuit breaker and fuse ratings on page 28
- 3.12 Sharing a breaker on page 28

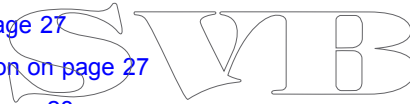

## 3.1 General cabling guidance

### Cable types and length

It is important to use cables of the appropriate type and length

- Unless otherwise stated use only standard cables of the correct type, supplied by Raymarine.
- Ensure that any non-Raymarine cables are of the correct quality and gauge. For example, longer power cable runs may require larger wire gauges to minimize voltage drop along the run.

### Routing cables

Cables must be routed correctly, to maximize performance and prolong cable life.

- Do NOT bend cables excessively. Wherever possible, ensure a minimum bend radius of 100 mm.

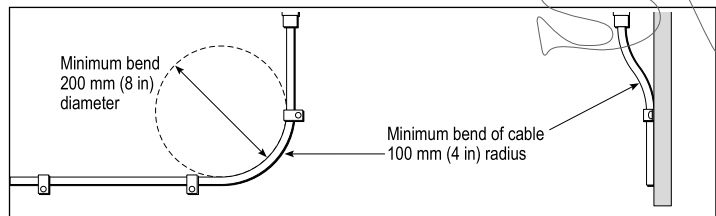

- Protect all cables from physical damage and exposure to heat. Use trunking or conduit where possible. Do NOT run cables through bilges or doorways, or close to moving or hot objects.
- Secure cables in place using tie-wraps or lacing twine. Coil any extra cable and tie it out of the way.
- Where a cable passes through an exposed bulkhead or deckhead, use a suitable watertight feed-through.
- Do NOT run cables near to engines or fluorescent lights.

Always route data cables as far away as possible from:

- other equipment and cables,
- high current carrying ac and dc power lines,
- antennae.

### Strain relief

Ensure adequate strain relief is provided. Protect connectors from strain and ensure they will not pull out under extreme sea conditions.

### Circuit isolation

Appropriate circuit isolation is required for installations using both AC and DC current:

- Always use isolating transformers or a separate power-inverter to run PC's, processors, displays and other sensitive electronic instruments or devices.
- Always use an isolating transformer with Weather FAX audio cables.
- Always use an RS232/NMEA converter with optical isolation on the signal lines.
- Always make sure that PC's or other sensitive electronic devices have a dedicated power circuit.

### Cable shielding

Ensure that all data cables are properly shielded that the cable shielding is intact (e.g. hasn't been scraped off by being squeezed through a tight area).

## 3.2 Radar scanner connection

The power and data cable connector is at the rear of the radar scanner unit.

Ensuring that the arrow on the power and data cable connector is aligned with the red triangular mark on the radar scanner connector, connect the cable to the scanners' connector, and fully hand-tighten. Do NOT use a wrench or any other tool.

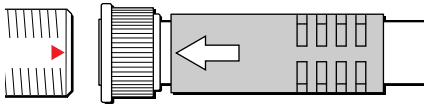

**Note:** If the antenna connector is disconnected after initial installation, Raymarine recommends that before reconnecting, you lightly coat the connector thread with Renolit Aqua 2 Calcium grease.

## 3.3 Product grounding

Important safety information for connections to ground.

Before applying power to this product, ensure it has been correctly grounded, in accordance with the instructions in this guide.

### Grounding requirements

These grounding requirements are applicable for Raymarine equipment supplied with a separate drain wire or screen.

- The product power cable drain conductor (screen) must be connected to a common ground point.
- It is recommended that the common ground point is a bonded ground, i.e. with the ground point connected to battery negative, and situated as close as possible to the battery negative terminal. If a bonded ground system is not possible, a non-bonded RF ground may be used.

### Bonded ground system (preferred)

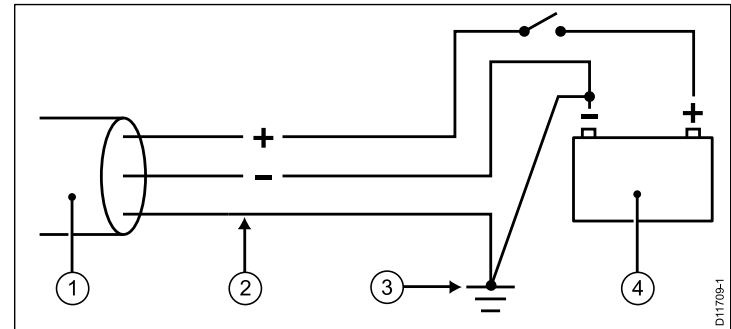

## RF ground system (alternative)

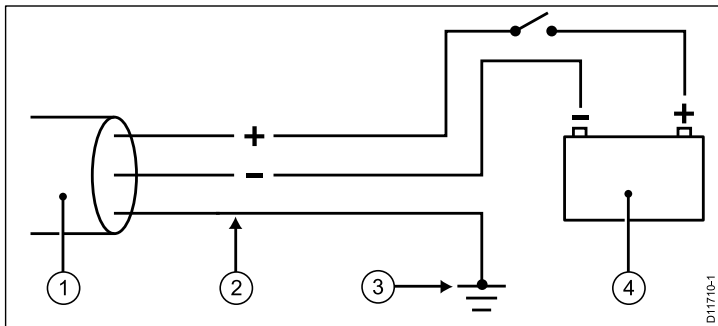

**Important:** Do NOT connect this product to a positively-grounded power system.

### References

- ISO10133/13297
- BMEA code of practice
- NMEA 0400

1. Power cable to product.
2. Drain (screen).
3. Bonded (preferred) or non-bonded RF ground.
4. Power supply or battery.

SVMB

### Implementation

If several items require grounding, they may first be connected to a single local point (e.g. within a switch panel), with this point connected via a single, appropriately-rated conductor, to the boat's common ground. The preferred minimum requirement for the path to ground (bonded or non-bonded) is via a flat tinned copper braid, with a 30 A rating (1/4 inch) or greater. If this is not possible, an equivalent stranded wire conductor maybe used, rated as follows:

- for runs of <1 m (3 ft), use 6 mm<sup>2</sup> (#10 AWG) or greater.
- for runs of >1 m (3 ft), use 8 mm<sup>2</sup> (#8 AWG) or greater.

In any grounding system, always keep the length of connecting braid or wires as short as possible.

## 3.4 Radar scanner power connections

Radar scanner power requirements.

The digital radar system is intended for use on ships' DC power systems operating from 12 to 24 Volts DC.

- All power connections must be made via the VCM100 Voltage Converter Module.
- The radar scanner must NOT be connected directly to a battery.
- The radar scanner must be connected directly to the VCM100 only.
- Only one radar scanner must be connected per VCM100 unit. Each radar scanner in your system requires a dedicated VCM100 unit.
- The power connection between the radar scanner and the VCM100 must be via an official Raymarine power and data digital cable (purchased separately).
- Do NOT cut and re-join any part of the power and data digital cable. A range of cable lengths and cable extensions is available for longer cable runs.
- The radar scanner must be connected to the POWER OUT terminals of the VCM100.
- The screen (drain) strands of the radar scanner's power and data digital cable must be connected to one of the VCM100 SCREEN terminals.

The following diagram illustrates the power connections of the power and data digital cable.

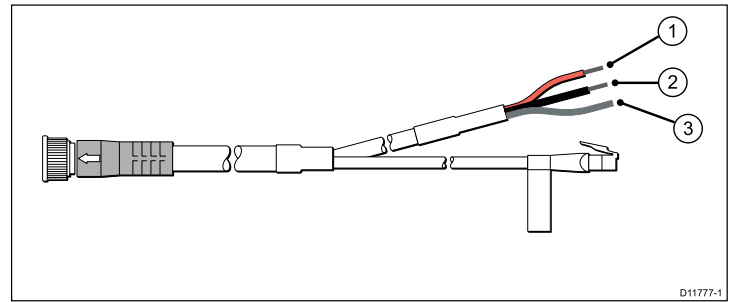

Item	Description
1	Red wire — connect to the positive POWER OUT terminal of the VCM100.
2	Black wire — connect to the negative POWER OUT terminal of the VCM100.
3	Screen (drain) strands — connect to one of the SCREEN terminals of the VCM100.

## 3.5 Radar scanner data connections

Radar scanner data connection requirements.

- For connections to a C-Series Widescreen multifunction display, a SeaTalk<sup>hs</sup> switch or crossover coupler must be used.
- For connections to a G-Series system, a SeaTalk<sup>hs</sup> switch must be connected between the radar scanner and the GPM400 processor module.
- For connections to a non-networked E-Series multifunction display, a SeaTalk<sup>hs</sup> crossover coupler must be used. An E-Series network containing more than a single connection requires a SeaTalk<sup>hs</sup> switch.
- The radar scanner must be connected to a SeaTalk<sup>hs</sup> switch or crossover coupler using the official Raymarine power and data digital cable (purchased separately).
- Additional SeaTalk<sup>hs</sup> cables may be required for connections between the power and data digital cable and a SeaTalk<sup>hs</sup> switch or crossover coupler.
- Do NOT cut and re-join any part of the power and data digital cable. A range of cable lengths and cable extensions is available for longer cable runs.

The following diagram illustrates the data connection of the power and data digital cable:

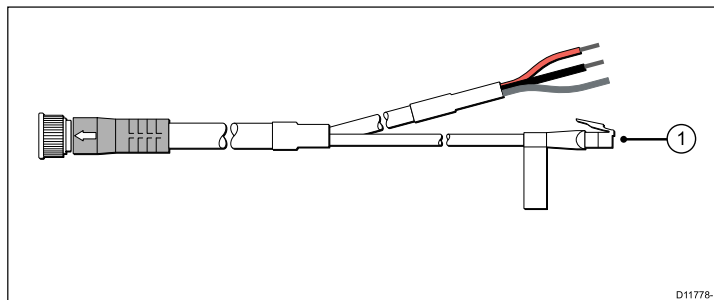

Item	Description
1	Data connection — connect to a SeaTalk <sup>hs</sup> switch or crossover coupler, as appropriate.

SVIB

## 3.6 Digital radar cable extension

If required you can use a Raymarine digital radar extension cable.

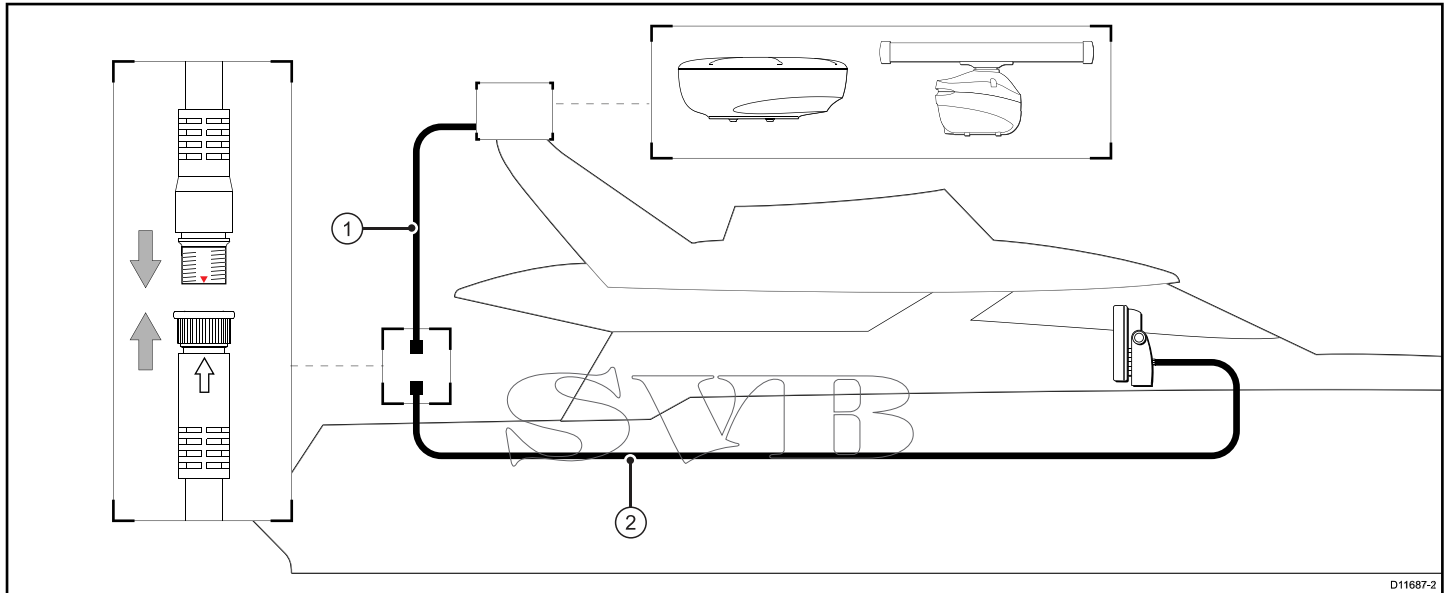

D11687-2

1. Extension cable
2. Power and data digital scanner cable (a SeaTalk<sup>hs</sup> switch or crossover coupler is also required between this cable and the display).

**Note:** The extension cable connects to the radar scanner.

**Note:** For Digital Open Array radar scanners, the power connections on the power and data digital cable **MUST** be connected to the VCM100 Voltage Converter Module (NOT shown in the diagram above).

## 3.7 Digital radar cables

For longer cable runs, a range of extensions is available for SeaTalk<sup>hs</sup> and radar scanner power and data digital cables.

**Note:** The maximum length for the radar power and data digital cable (including all extensions) is 25 m (82 ft).

### Radar scanner to SeaTalk<sup>hs</sup> switch (or crossover coupler)

#### Digital scanner cables

Connect the Radar scanner to the SeaTalk<sup>hs</sup> switch (or crossover coupler) and power supply. These cables contain both power and data wires.

Cable	Part number	Notes
5 m (16.4 ft) Digital cable	A55076	
10 m (32.8 ft) Digital cable	A55077	
15 m (49.2 ft) Digital cable	A55078	
25 m (82.0 ft) Digital cable	A55079	

#### Extension cables

Use of one of these cables to extend the radar connection to the SeaTalk<sup>hs</sup> switch (or crossover coupler) and power supply. These cables contain both power and data wires.

Cable	Part number	Notes
2.5 m (8.2 ft) extension cable	A92141	
5 m (16.4 ft) extension cable	A55080	
10 m (32.8 ft) extension cable	A55081	

### SeaTalk<sup>hs</sup> switch (or crossover coupler) to display unit

#### SeaTalk<sup>hs</sup> network cables

Connect from the SeaTalk<sup>hs</sup> switch or the crossover coupler into the rear of the display.

Cable	Part number	Notes
1.5 m (4.9 ft) SeaTalk <sup>hs</sup> network cable	E55049	
5 m (16.4 ft) SeaTalk <sup>hs</sup> network cable	E55050	
10 m (32.8 ft) SeaTalk <sup>hs</sup> network cable	E55051	
20 m (65.6 ft) SeaTalk <sup>hs</sup> network cable	E55052	

#### SeaTalk<sup>hs</sup> hardware

To connect the digital radar to a multifunction display you will need to include one of the following:



Cable	Part number	Notes
SeaTalk <sup>h</sup> s switch	E55058	8-way hub for network connection of multiple SeaTalk <sup>h</sup> s devices.
SeaTalk <sup>h</sup> s coupler	E55060	Coupler for connection of a single SeaTalk <sup>h</sup> s device.

## 3.8 VCM100 power connections

VCM100 power and grounding requirements.

The VCM100 is intended for use on ships' DC power systems operating from 12 to 24 Volts DC.

- The VCM100 must be connected to a battery isolator switch, or a DC distribution panel.
- The battery isolator switch or DC distribution panel must be connected to the POWER IN terminals of the VCM100.
- Do NOT connect additional power switches to the cable providing the power feed to the VCM100.
- All power connections between the VCM100 and the power source must have appropriate fuse protection.
- All power connections must be of high quality to minimize resistance and to remove the risk of accidental shorts.
- The VCM100 SCREEN terminals must be connected to your vessel's RF ground system.
- Do NOT connect the radar scanner or the VCM100 to a positively-grounded power system.

The following diagram illustrates the power connections of the VCM100.

SVMP

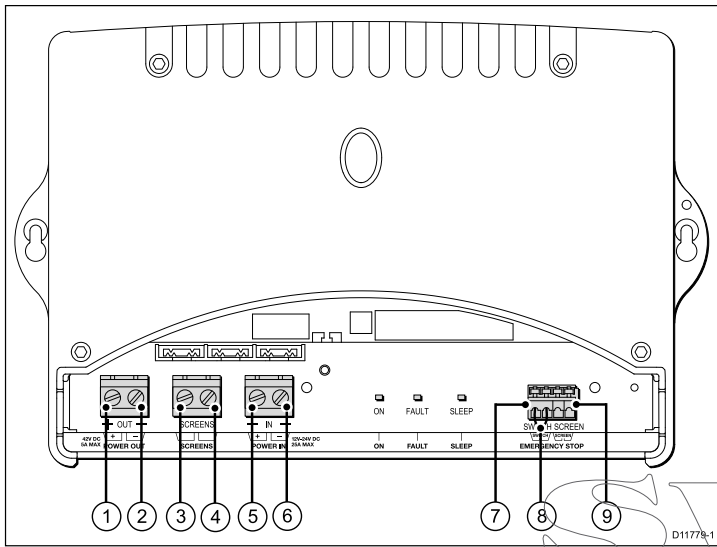

Item	Description
6	POWER IN (Negative) — connect to the negative battery terminal.
7	EMERGENCY STOP (Switch) — if you have the optional VCM100 emergency stop button, remove the wire bridging link from the VCM100 EMERGENCY STOP terminals, and connect the emergency stop button SWITCH wire to the VCM100 EMERGENCY STOP SWITCH terminal.
8	EMERGENCY STOP wire bridging link— only remove if fitting the optional emergency stop button.
9	EMERGENCY STOP (Screen) — if you have the optional VCM100 emergency stop button, remove the wire bridging link from the VCM100 EMERGENCY STOP terminals, and connect the emergency stop button SCREEN (drain) wire to the VCM100 EMERGENCY STOP SCREEN terminal.

Item	Description
1	POWER OUT (Positive) — connect to the RED wire of the power and data digital cable.
2	POWER OUT (Negative) — connect to the BLACK wire of the power and data digital cable.
3	SCREEN — connect to the bare screen (drain) strands of the power and data digital cable.
4	SCREEN — connect to your vessel's RF ground system.
5	POWER IN (Positive) — connect to the positive terminal of the DC distribution panel or battery isolator switch.

### 3.9 VCM100 power cable extension

The power cable can be extended for longer cable runs between the VCM100 and your vessel's DC distribution panel or battery isolator switch.

If you need to extend the power cable, use a splash proof junction box. The junction box should provide a terminal strip with sufficient space for power connections. The terminal strip should be a minimum of 30 Amp rating for power cores. It is essential that both power cores and the screen (drain) are connected and that the connection is of very low resistance as considerable power passes through this connection.

The following table provides recommended total power cable lengths and gauges. These figures relate to the maximum distance of power cables from the battery isolator switch or DC distribution panel to the VCM100. Exceeding these lengths may cause unreliable operation.

AWG (American Wire Gauge)	mm <sup>2</sup>	Maximum distance (12 volt supply)	Maximum distance (24 volt supply)
7	10.55	15 m (49.2 ft.)	55 m (180.4 ft.)
8	8.36	10 m (32.8 ft.)	40 m (131.2 ft.)
10	5.26	8 m (26.2 ft.)	32 m (104.9 ft.)
11	4.17	6 m (19.6 ft.)	24 m (78.7 ft.)

**Note:** If the required extensions result in unacceptably large diameter cables, use two or more smaller gauge wires to achieve the required copper wire cross-section. For example, using two pairs of 2 mm<sup>2</sup> cables is equivalent to using two single 4 mm<sup>2</sup> cables.

### 3.10 VCM100 screen (drain) wire extension

The screen (drain) wire can be extended for longer cable runs between the VCM100 and your vessel's RF ground system.

Extensions to the screen (drain) wire should use an 8 mm braid or AWG 10 (5.26 mm<sup>2</sup>) multi-stranded cable.

## 3.11 Circuit breaker and fuse ratings

Battery isolator switch, thermal breaker, and fuse ratings.

All power connections between the VCM100 and its power source must be protected by a thermal circuit breaker or fuse, fitted close to the power connection. The connection from the output of the VCM100 to the digital radar does not require a fuse or circuit breaker.

If you do not have a thermal circuit breaker or fuse in your power circuit (fitted to the DC distribution panel, for example), you **MUST** fit an in-line breaker or fuse to the positive wire of the power cable.

The following table provides suitable ratings for battery isolator switches, circuit breakers, and fuses.

Power supply	Device	4 kW scanner	12 kW scanner
12 volt	Isolator switch	30 amps (minimum rating)	30 amps (minimum rating)
	Thermal breaker	15 amps	15 amps
	Fuse	20 amps	20 amps
24 volt	Isolator switch	15 amps (minimum rating)	15 amps (minimum rating)
	Thermal breaker	8 amps	8 amps
	Fuse	10 amps	10 amps

## 3.12 Sharing a breaker

Where more than 1 piece of equipment shares a breaker you must provide protection for the individual circuits. E.g. by connecting an in-line fuse for each power circuit.

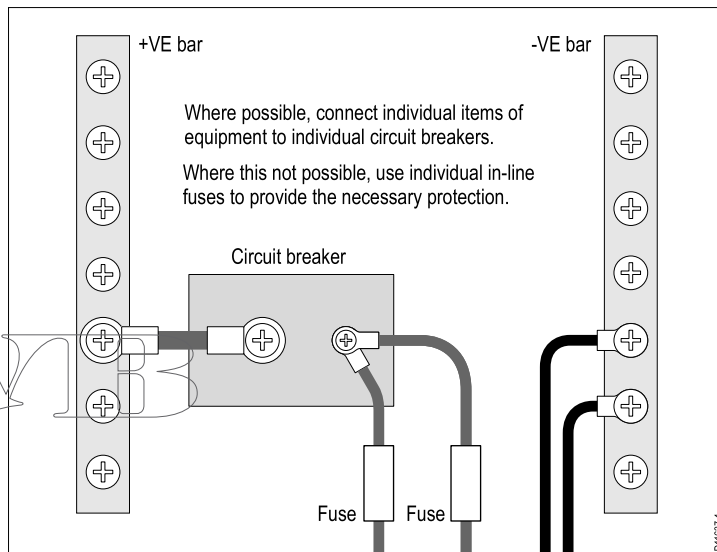

# Chapter 4: Location and mounting

## Chapter contents

- [4.1 Selecting a location on page 30](#)
- [4.2 Mounting on page 34](#)

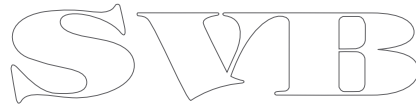

## 4.1 Selecting a location



### **Warning: Potential ignition source**

This product is NOT approved for use in hazardous/flammable atmospheres. Do NOT install in a hazardous/flammable atmosphere (such as in an engine room or near fuel tanks).

### **VCM100 location requirements**

When selecting a mounting location it is important to consider a number of factors.

#### **Ventilation**

- Ensure that equipment is mounted in a compartment of suitable size.
- Ensure that ventilation holes are not obstructed. Allow adequate separation of equipment.

#### **Mounting surface**

Ensure equipment is adequately supported on a secure surface. Do not mount units or cut holes in places which may damage the structure of the vessel.

#### **Cables**

Ensure the unit is mounted in a location which allows proper routing and connection of cables:

- Minimum bend radius of 100 mm (3.94 in) unless otherwise stated.
- Use cable supports to prevent stress on connectors.
- The maximum length of cable between the battery and the VCM100 should not normally exceed 19.6 ft. (6 M). All power cable lengths should be kept as short as possible.

#### **Water ingress**

The VCM100 is splashproof, and suitable for mounting below decks only.

#### **Electrical interference**

Select a location that is far enough away from devices that may cause interference, such as motors, generators and radio transmitters/receivers.

#### **Magnetic compass**

Mount the VCM100 at least 3 ft (1 m) away from a magnetic compass.

#### **Power supply**

Select a location that is as close as possible to the vessel's DC power source. This will help to keep cable runs to a minimum.

### **Radar scanner location requirements**

When selecting a location it is important to consider a number of factors.

#### **Horizontal position**

The radar scanner should be positioned as near as possible to your vessel's centerline.

#### **Height**

The radar scanner should normally be mounted as high as practical above the waterline:

- Mount the scanner above head height out of range of personnel, to avoid mechanical danger and minimize exposure to electromagnetic radiation.
- Radar operates at the line-of-sight, so a high mounting position gives better long range performance.

- Surrounding large objects, in the same horizontal plane, can interfere with the radar signal and cause blind areas or shadow sectors and false targets on the radar display (see below).

Do not mount the radar scanner so high that it is affected by the pitching and rolling of the vessel.

### **Shadow areas and false echoes**

Mount the radar scanner away from large structures or equipment, such as engine stacks, searchlights, horns, or masts. These objects may cause shadow areas and false echoes. For example, if you mount the radar scanner on a mast, echoes from other targets may be reflected from the mast. Wet sails may also cause shadow areas, so radar performance may be reduced in the rain. It is particularly important to avoid shadow areas near the bow. Raising or even lowering the radar scanner may help to reduce these effects.

In shadow areas beyond the obstruction there will be a reduction of the beam intensity. There may be a blind sector if the beam intensity is not sufficient to obtain an echo from an object. This may occur even at close range. For this reason the angular width and relative bearing of any shadow area must be determined at installation.

You may be able to detect shadow areas or false echoes on your multifunction display. For example, sea clutter can be used as a good indicator of blind arcs. Dark sectors on the radar display indicate possible shadowed areas. This information should be posted near the display unit and operators must be alert for targets in these blind areas.

### **Access**

The radar scanner should be easily accessible to allow maintenance to be carried out safely. Sufficient clearance must be allowed to fully open the scanner unit for maintenance and service.

### **Mounting platform**

The radar scanner must be mounted on a rigid and stable platform. The platform must be capable of supporting the mass and inertia

of the radar scanner under seagoing conditions. The platform should not twist (causing bearing errors) or be subject to excessive vibration.

The mounting site must be clear of the following:

- Ropes.
- Moving rigging.
- Heat.
- Fumes.
- People.

### **Magnetic compass**

Mount the radar scanner at least 1 m away from a magnetic compass.

### **Multiple radar scanners**

If two radar scanners are installed at different locations in a dual radar system, care should be taken to allow for the difference in position of the radars when switching between the two on your multifunction display. This is especially noticeable at short ranges on larger vessels.

### **Cables**

- All cables should be adequately clamped and protected from physical damage and exposure to heat. Avoid running cables through bilges or doorways, or close to moving or hot objects.
- Where a cable passes through an exposed bulkhead or deckhead, use a watertight feed-through.

## Radar scanner dimensions

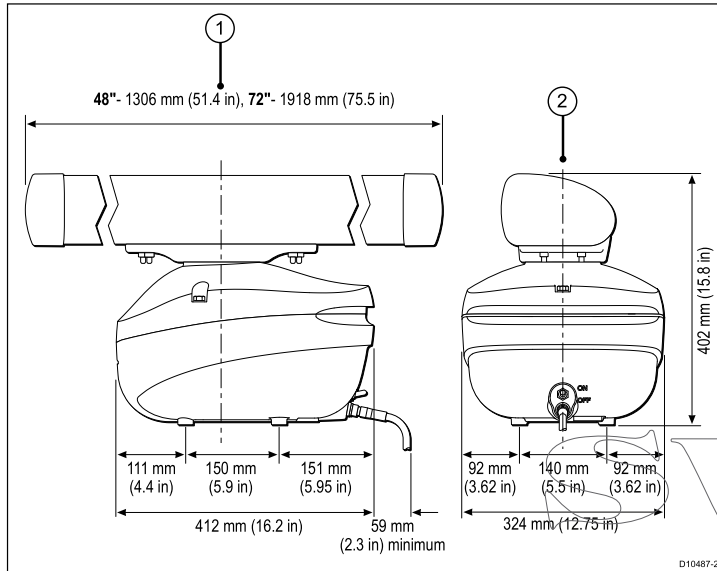

Item	Description
1	Maximum rotation
2	Center of rotation

## Radar scanner mounting surface

Suitable radar scanner mounting surfaces include a mast platform, an arch, or a bridge structure.

If mounting the radar scanner on a sailboat, it may be necessary to install a radar guard to prevent the sails or any rigging coming

into contact with the radar scanner or mounting platform. Without a proper radar guard the mounting platform and the radar scanner could be severely damaged.

The following diagram illustrates suitable mounting surfaces for the radar scanner:

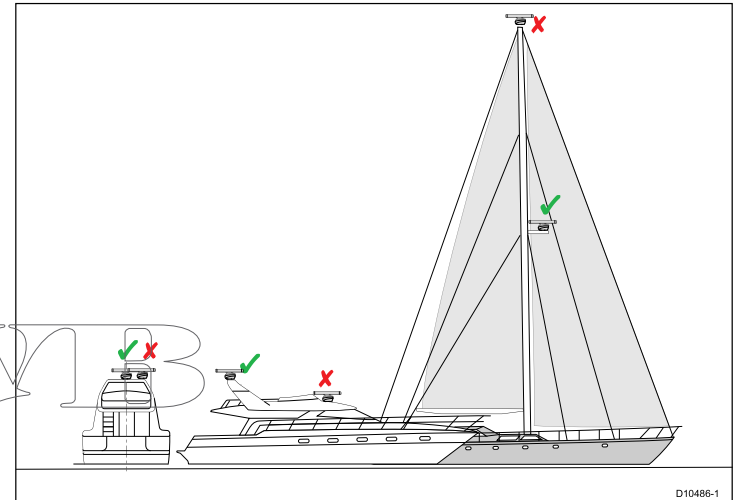

## Radar scanner mounting angle

Ensure the radar scanner rotates parallel to the water line.

The radar beam from the radar scanner is approximately 25° wide in the vertical direction, to give good target detection even when your vessel pitches and rolls.



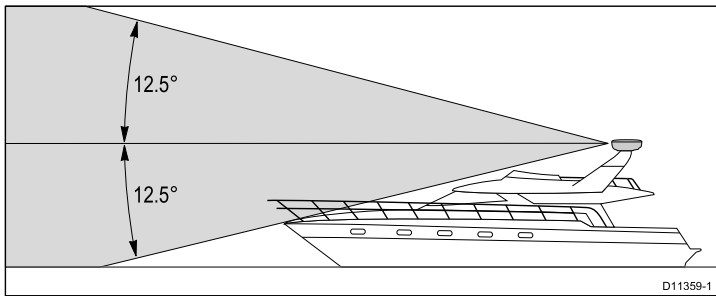

Planing hull vessels, and some displacement hull vessels, adopt a higher bow angle when the vessel is at cruising speed. This may raise the radar's main radiation angle, and can cause poor detection of nearby targets. It may be necessary to compensate for the bow rise to ensure optimum target detection. This can be achieved by fitting a wedge or washers between the mounting platform and the base of the radar scanner, so that the radar beam remains parallel to the water line when the vessel's bow rises at cruising speed.

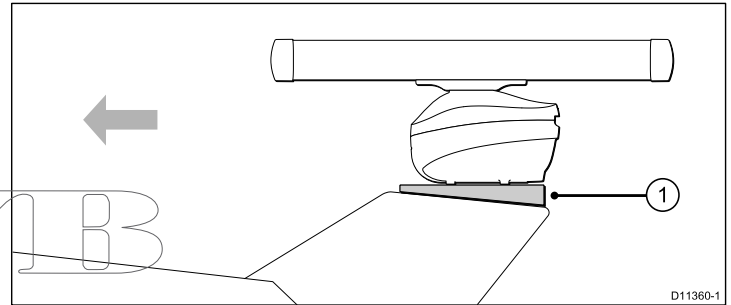
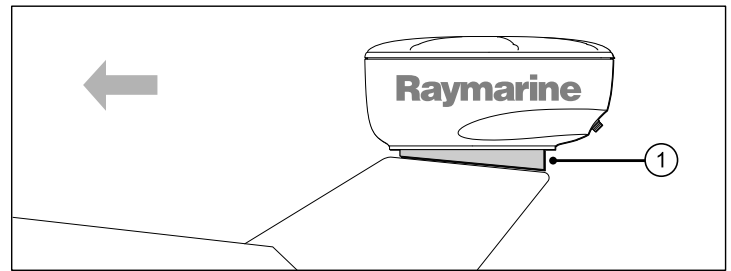

Item	Description
1	Wedge or washers

## 4.2 Mounting

### Radar scanner installation procedures

Important installation information.

The radar scanner is supplied in 3 parts, each involving a separate installation procedure:

1. Install the VCM100 voltage converter module.
2. Secure the radar pedestal to a suitable mounting platform.
3. Attach the antenna to the pedestal.

### Mounting the VCM100

Before mounting the unit, ensure that you have:

- Selected a suitable location.
- Identified the cable connections and route that the cables will take.

**Note:** Do NOT connect any cables to the power supply until the following steps have been completed.

1. Check the selected location for the unit. The VCM100 requires a clear, flat area with suitable space for routing the cables below the unit.
2. Hold the VCM100 in place in the required mounting location.
3. Using a pencil, mark the drilling area inside the mounting lug on each side of the VCM100 unit.
4. Using a 3 mm drill bit, drill a hole through the pencil marks.
5. Align the VCM100 mounting lugs with the drill holes.
6. Hold the VCM100 in place.
7. Using a suitable screwdriver, screw the self-tapping mounting screws through the mounting lug holes, into the drilled holes.
8. Connect the cables, according to the instructions provided in this handbook.

9. Hold the cable clamp in place over the cables, approximately 50 mm (2") below the mounted VCM100 unit.
10. Using a pencil, mark the drilling area inside each mounting bracket hole.

ENSURE THE CABLES DO NOT COVER THE HOLES.

11. Using a 3 mm drill bit, drill a hole through the pencil marks.
12. Hold the cable clamp in place, each hole aligned with the drill holes.
13. Using a suitable screwdriver, screw the self-tapping mounting screws through the bracket holes, into the drilled holes.

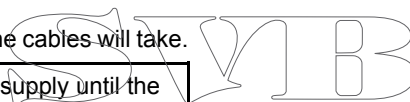

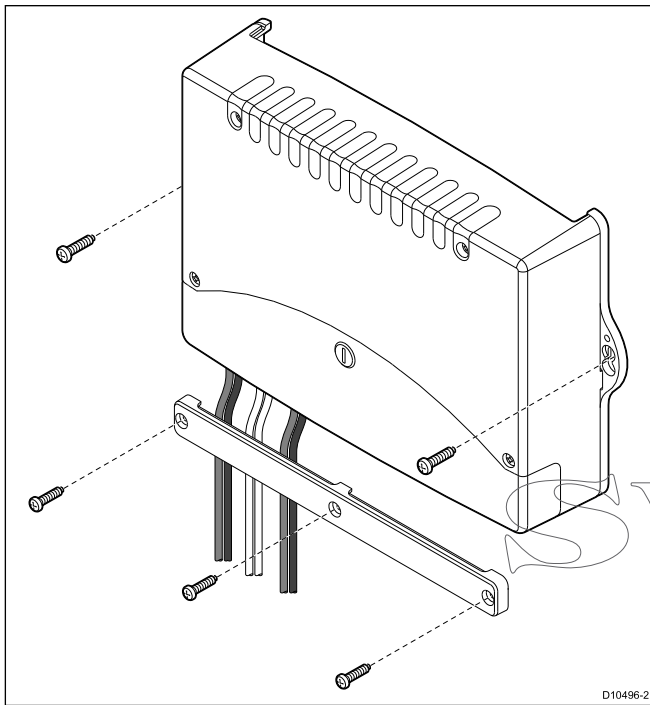

– 48" Radar - 25 kg (55.1 lb)

– 72" Radar - 29 kg (63.9 lb)

For safety reasons it is recommended that the unit is not lifted by one person. The unit is supplied with lifting eyes (maximum Safe Working Load (SWL) = 40 kg) to facilitate the use of standard lifting accessories, such as a rope, chain or strop. The SWL of the lifting accessories should be a minimum of 150 kg. Suitable lifting equipment could include a crane, hoist, or an appropriate rigid overhead structure. Do NOT attach the antenna to the pedestal prior to lifting.

**Note:** Do NOT connect any cables until the following steps have been completed.

1. Check the selected location. A clear, flat platform is required for mounting the pedestal unit.
2. Fix the supplied mounting template to the platform, using masking or self-adhesive tape.

## Securing the pedestal to the mounting platform

Before mounting the unit, ensure that you have:

- Selected a suitable location.
- Identified the cable connections and route that the cables will take.
- Prepared suitable lifting equipment for fixing the pedestal to the mounting platform. The digital radar weighs in total (with antenna fitted):

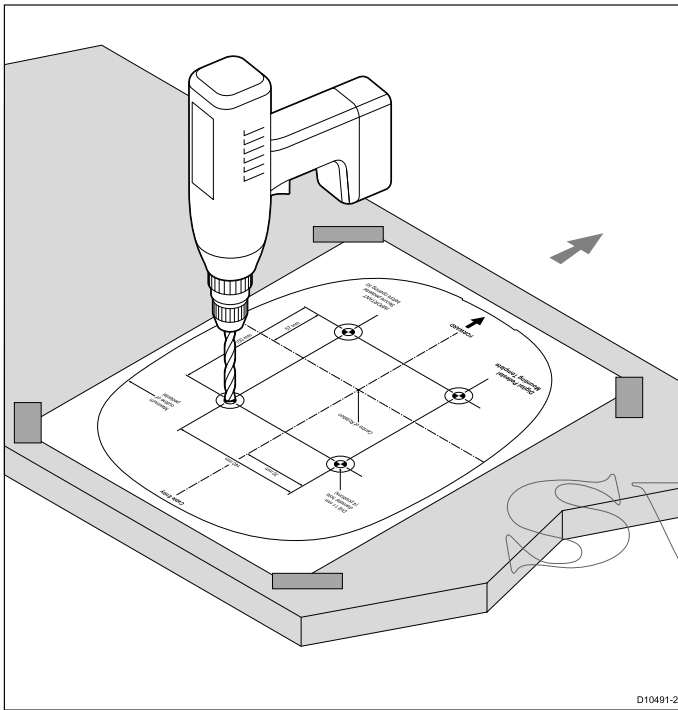

- Using a 3 mm drill bit, drill the 4 holes, as indicated on the mounting template.

Check that the holes have been drilled in the correct position.

- Using an 11 mm drill bit, drill through the 4 holes.
- Remove the mounting template.
- Ensure the lifting eyes are fitted to the pedestal. To fit a lifting eye, remove the securing bolt, place the lifting eye in position, and then secure the lifting eye with the bolt, to 7 Nm (5.2 lb ft) torque.

- The pedestal unit has a cap fitted over the open array mounting shaft to protect the protruding coaxial pin. This cap must be left in place until the open array antenna is fitted to the pedestal.
- Grease the 4 metal studs with the supplied Denso paste.

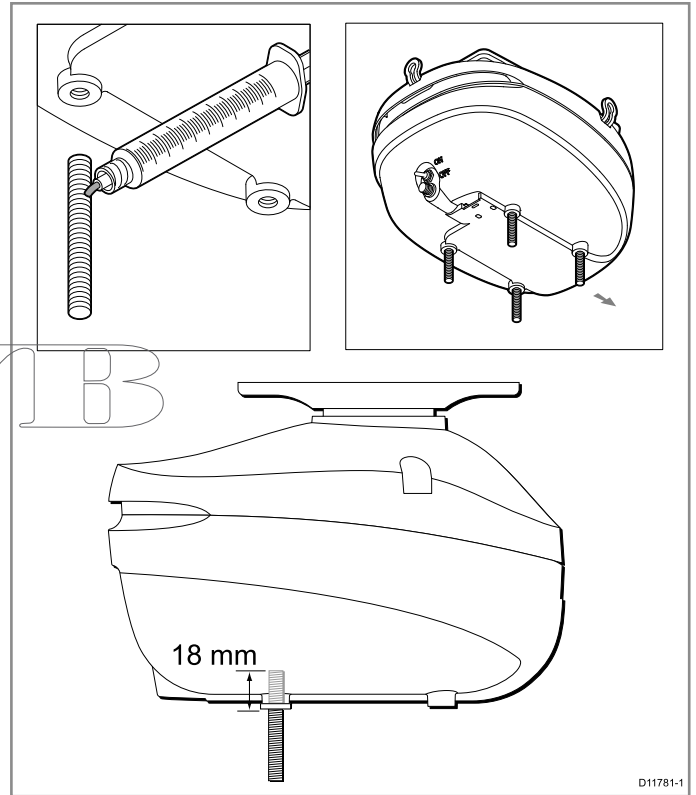

- Insert the studs no more than 18 mm into the holes in the pedestal base, and hand-tighten. 4 spare nuts are provided

which may be used as temporary locking nuts to aid insertion of the studs into the pedestal.

If the supplied studs are not long enough for the mounting surface thickness, use M10 stainless steel, grade A4-70 studding of a suitable length.

10. Using suitable lifting equipment (such as a rope or chain) attached to the lifting eyes, raise the pedestal over the mounting surface. Carefully lower into position, taking care that the studs pass through the holes without damaging the threads. Ensure that the front of the pedestal is pointing towards the bow of the vessel.

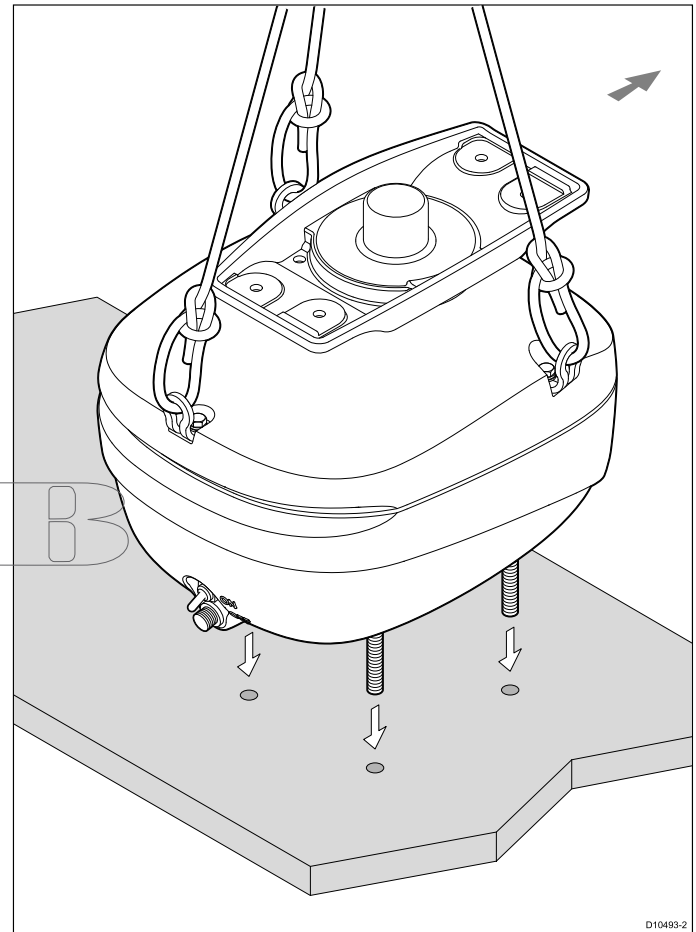

11. Grease the studs with the supplied Denso paste.

12. Referring to the following illustration, use the 4 nuts and associated washers to secure the pedestal to the platform. Tighten each nut to 30 Nm (22.1 lb ft) torque.

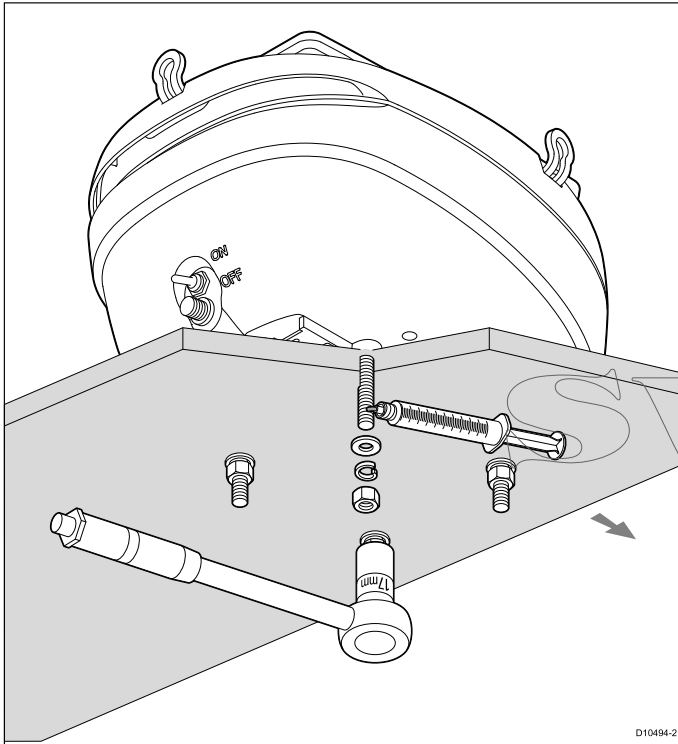

13. Ensure all 4 sets of nuts and washers are used to secure the pedestal to the mounting platform. There should be no more than 6 mm of excess stud below the nut. Cut-off any excess stud.

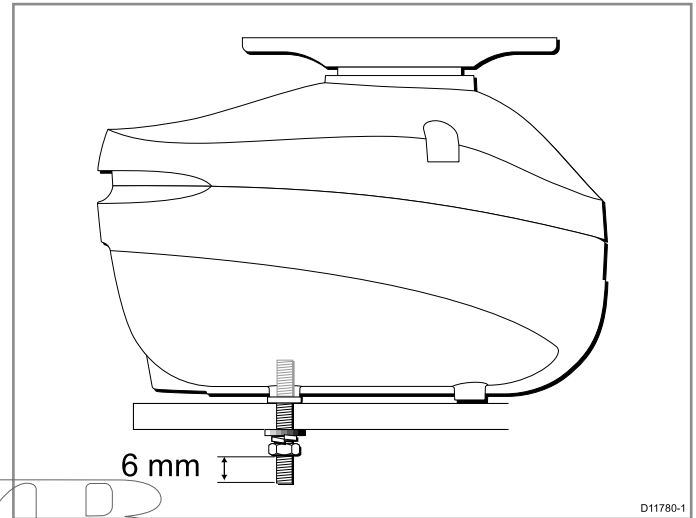

14. Retain the 4 spare nuts (which may have been used as a temporary measure during Step 9).

## Removing the radar pedestal lifting eyes

On the pedestal unit:

1. Loosen the first lifting eye securing bolt, enough to remove the lifting eye.
2. Once the lifting eye is removed, re-tighten the bolt to 7 Nm (5.2 lb ft) torque.
3. Repeat Steps 1 to 2 to remove all lifting eyes.

## Securing the radar antenna to the pedestal

Before attaching the antenna to the pedestal unit, ensure that:

- The pedestal base is securely fixed to the platform.
- The cable is NOT attached.
- The pedestal power switch is in the OFF position.
- The pedestal unit has a cap fitted over the open array mounting shaft to protect the protruding co-axial pin. This cap must remain in place until you're ready to fit the antenna to the pedestal unit.

**Note:** You MUST ensure that the antenna does not come into contact with the delicate protruding coaxial pin. This is a critical component and should be treated with caution. Follow all the instructions provided below, and ensure that the alignment guides are used.

1. Fit the 4 threaded alignment guides to the studs on the underside of the antenna. Ensure a close fit. The alignment guides are essential to help prevent damage to the coaxial pin.
2. Remove the protective cap from the antenna shaft. Retain the cap for future use.
3. Position the antenna mounting bracket on the Port to Starboard axis of the pedestal.
4. Lift the antenna into position, ensuring it is in the correct orientation and that the threaded alignment guides are fitted. Carefully align and slowly lower the antenna.
5. Once the antenna is in position, remove the alignment guides.
6. Grease the 4 securing studs with the supplied Denso paste.
7. Use the 4 nuts and associated washers to secure the antenna to the pedestal, as shown in the following diagram. Tighten each nut to 10 Nm (7.4 lb ft) torque.

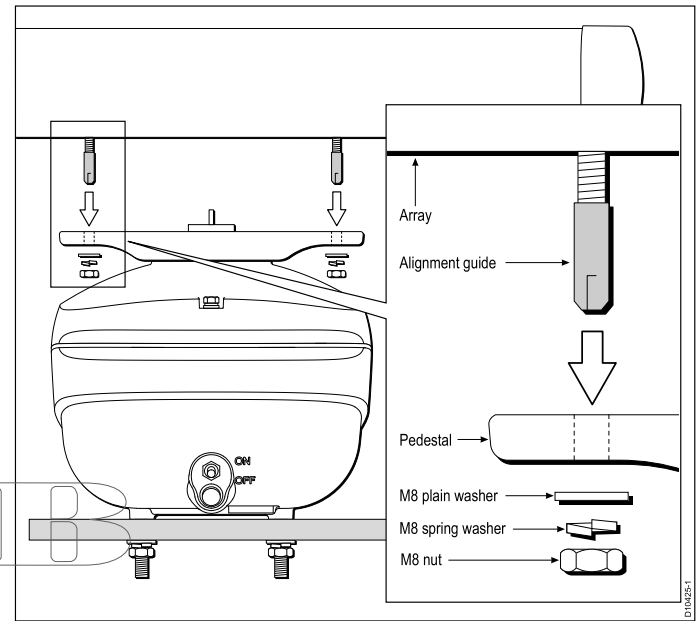

SVIB



# Chapter 5: System checks

## Chapter contents

- 5.1 Radar scanner initial power on test on page 42
- 5.2 Radar check on page 42

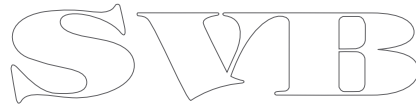

## 5.1 Radar scanner initial power on test

With all cables correctly and securely connected to the radar scanner, and access to a multifunction display (power OFF):

1. Ensure the radar scanner power switch is set to ON.
2. Power on the multifunction display.

The magnetron warm-up sequence should start, after which the radar scanner should enter Standby mode.

3. If necessary, adjust the lighting and contrast on the multifunction display.

## 5.2 Radar check



### Warning: Radar scanner safety

Before rotating the radar scanner, ensure all personnel are clear.



### Warning: Radar transmission safety

The radar scanner transmits electromagnetic energy. Ensure all personnel are clear of the scanner when the radar is transmitting.

## Checking the radar

1. Select a Radar page.

The Radar scanners will now initialize in standby mode, this process will take approximately 70 seconds.

2. Press the **POWER** button.
3. Press the **Radar Tx/Stdby** softkey and set to Tx.

The scanners should now be transmitting and receiving.

4. Check that the radar screen is operating correctly.

STOP

## Typical HD digital radar screen

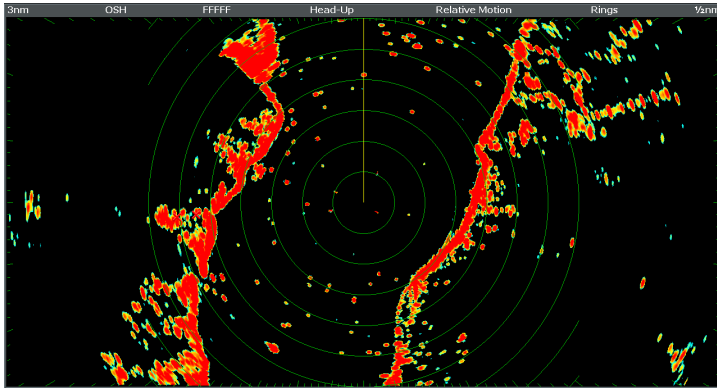

**Note:** The example above is representative of the enhanced output provided by a HD digital radar scanner.

### Points to check:

- Radar sweep with echo responses are shown on screen.
- Radar status icon rotating in top right hand corner.

## Check and adjust bearing alignment

### Bearing alignment

The radar bearing alignment ensures that radar objects appear at the correct bearing relative to your boat's bow. You should check the bearing alignment for any new installation.

## Example misaligned radar

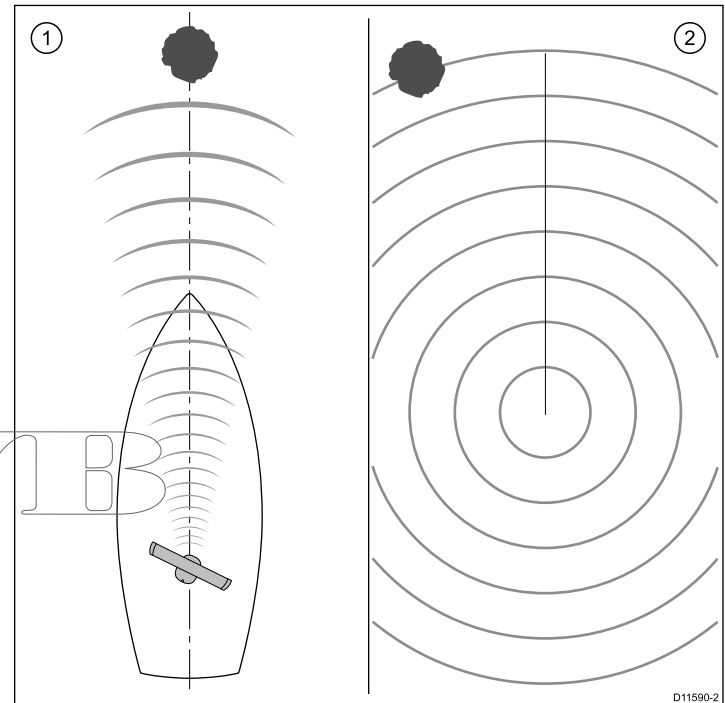

Item	Description
1	Target object (such as a buoy) dead ahead.
2	Target displayed on the radar display is not aligned with the Ship's Heading Marker (SHM). Bearing alignment is required.

## Checking the bearing alignment

1. With your vessel under way: Align the bow with a stationary object identified on the radar display. An object between 1 & 2 NM distant is ideal.
2. Note the position of the object on the radar display. If the target is not under the ship's heading marker (SHM), there is an alignment error and you will need to carry out bearing alignment adjustment.

## Adjusting the bearing alignment

Once you have checked the bearing alignment you can proceed and make any required adjustments.

With the radar page displayed:

1. Select the **RADAR SETUP > BEARING ALIGNMENT** menu.
2. Press the **BEARING ALIGNMENT** softkey.
3. Use the rotary control to place the selected target under the Ship's Heading Marker.
4. Press **OK** when complete.



from the front of the vessel) when you place it in either standby or switch it off.

3. Press **OK** when complete.

## Adjusting radar offset (parking)

This setting is applicable to open array scanners. It is used to ensure the scanner parks in the correct position when rotation stops.

Before you proceed, ensure that:

- The radar page is selected
- The radar scanner is initialized standby mode

1. Press the **RADAR SETUP > SCANNER SETUP**.
2. Select the **PARKING OFFSET** option, then adjust the offset angle required to park the radar so that the antenna comes to rest facing forward (you should see the Raymarine logo wording

# Chapter 6: Troubleshooting

## Chapter contents

- [6.1 Troubleshooting on page 46](#)
- [6.2 Power up troubleshooting on page 47](#)
- [6.3 Radar troubleshooting on page 48](#)
- [6.4 System data troubleshooting on page 49](#)
- [6.5 VCM100 LED indications on page 50](#)
- [6.6 SeaTalk<sup>hs</sup> LED indications on page 50](#)

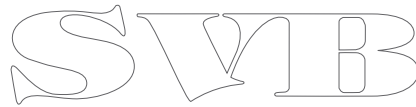

## 6.1 Troubleshooting

The troubleshooting information provides possible causes and corrective action required for common problems associated with marine electronics installations.

All Raymarine products are, prior to packing and shipping, subjected to comprehensive test and quality assurance programs. However, if you experience problems with the operation of your HD and SuperHD Digital Open Array radar scanner, this section will help you to diagnose and correct problems in order to restore normal operation.

If after referring to this section you are still having problems with your unit, please contact Raymarine Technical Support for further advice.

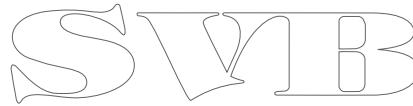

## 6.2 Power up troubleshooting

Problems at power up and their possible causes and solutions are described here.

Problem	Possible causes	Possible solutions
The display does not start up.	Problem with power to the unit.	Check relevant fuses and breakers.
		Check that the power supply cable is sound and that all connections are tight and free from corrosion.
		Check that the power source is of the correct voltage and sufficient current.

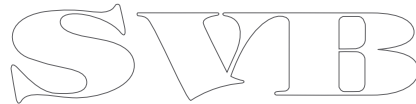
The logo consists of the letters 'S', 'V', 'M', and 'B' in a stylized, outlined font. The 'S' is on the left, followed by 'V', 'M', and 'B' to its right. The letters are interconnected and have a decorative, slightly gothic or serif-like appearance.

## 6.3 Radar troubleshooting

Problems with the radar and their possible causes and solutions are described here.

Problem	Possible causes	Possible solutions
No Data or No scanner message	Radar scanner power supply	Check that the scanner power supply cable is sound and that all connections are tight and free from corrosion.
		Check relevant fuses and breakers.
		Check power source is of the correct voltage and sufficient current (using voltage booster if appropriate).
	SeaTalk <sup>hs</sup> network problem	Check that the Scanner is correctly connected to the display via a crossover coupler or SeaTalk <sup>hs</sup> switch.
		Check the status of the SeaTalk <sup>hs</sup> Switch.
		Check that SeaTalk <sup>hs</sup> cables are free from damage.
Software mismatch between equipment may prevent communication.	Contact Raymarine technical support.	
Switch at scanner pedestal in OFF position	Ensure scanner pedestal switch is in ON position.	
Radar will not initialize (Voltage control module (VCM) stuck in "sleep mode")	Intermittent or poor power connection	Check power connection at VCM. (Voltage at input = 12 / 24 V, Voltage at output = 40 V)
The bearing of a target on the radar screen is incorrect.	The radar bearing alignment requires correcting.	Check and adjust radar bearing alignment.



## 6.4 System data troubleshooting

Aspects of the installation can cause problems with the data shared between connected equipment. Such problems, their possible causes and solutions are described here.

Problem	Possible causes	Possible solutions
Instrument, engine or other system data is unavailable at all displays.	Data is not being received at the display.	Check the data bus (e.g. SeaTalk <sup>ng</sup> ) wiring and connection to the display.
		Check the overall integrity of the data bus (e.g. SeaTalk <sup>ng</sup> ) wiring.
		If available refer to the reference guide for the data bus. (e.g. SeaTalk <sup>ng</sup> reference manual)
	Data source (e.g ST70 instrument or engine interface) is not operating.	Check the source of the missing data (e.g. ST70 instrument or engine interface).
		Check the power to the SeaTalk bus.
		Refer to the manufacturer's handbook for the equipment in question.
Software mismatch between equipment may prevent communication.	Contact Raymarine technical support.	
Instrument or other system data is missing from some but not all displays.	SeaTalk <sup>hs</sup> network problem	Check that all required equipment is connected to the SeaTalk <sup>hs</sup> switch.
		Check the status of the SeaTalk <sup>hs</sup> Switch.
		Check that SeaTalk <sup>hs</sup> cables are free from damage.
	Software mismatch between equipment may prevent communication.	Contact Raymarine technical support

## 6.5 VCM100 LED indications

LED indications associated with the VCM100.

LED name	LED color / state	Possible causes
On	Green / solid	Radar operating normally.
Fault	Red / solid	Fault condition.
Sleep	Yellow / flashing	Radar scanner in standby.
	Yellow / solid	Fault condition, unit self-recovers after 20 seconds.

## 6.6 SeaTalk<sup>hs</sup> LED indications

LED indications associated with the SeaTalk<sup>hs</sup> switch are described here.

LED state	Possible causes
For all connected channels: 1 steady and 1 flashing green LED.	No problem detected (Steady LED indicates network connection Flashing LED indicates network traffic) .
No LEDs are illuminated.	No power to the SeaTalk <sup>hs</sup> switch.
Some LEDs are not illuminated.	<ul style="list-style-type: none"> <li>• Cable / connection faults on the channels with non-illuminated LEDs.</li> <li>• Equipment connected to non-illuminated LEDs may be faulty.</li> </ul>

SIVIB

# Chapter 7: Technical support

## Chapter contents

- [7.1 Raymarine technical support on page 52](#)

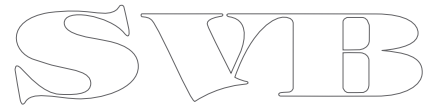

## 7.1 Raymarine technical support

Raymarine provides a comprehensive customer support service, on the world wide web, through our worldwide dealer network and by telephone help line. If you are unable to resolve a problem, please use any of these facilities to obtain additional help.

### Web support

Please visit the customer support area of our website at:

[www.raymarine.com](http://www.raymarine.com)

This contains Frequently Asked Questions, servicing information, e-mail access to the Raymarine Technical Support Department and details of worldwide Raymarine agents.

### Telephone support

In the USA call:

+1 603 881 5200 extension 2444

In the UK, Europe, the Middle East, or Far East call:

+44 (0)23 9271 4713

### Product information

If you need to request service, please have the following information to hand:

- Product name.
- Product identity.
- Serial number.
- Software application version.

You can obtain this product information using the menus within your product.

## Viewing multifunction display software information

1. Press the **MENU** button.
2. Select **System Diagnostics**.
3. Select **Software Services**.
4. Select **Unit Info**.

A range of information is displayed, including the App Version (software version).



# Chapter 8: Technical specification

## Chapter contents

- [8.1 Technical specification on page 54](#)

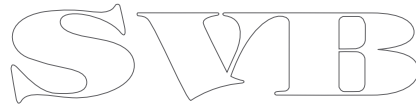

## 8.1 Technical specification

### Approvals

Region	Certification
USA	47CFR FCC Part 2 & Part 80 Certificate of Approval
Canada	RSS138 Iss. 1 Technical Acceptance Certificate
European Union & EFTA	R & TTE directive 1999/5/EC Certificate of Opinion
Australia / New Zealand	ACMA Declaration of Conformity Compliance level 3

### General

	48" 4kW HD or SuperHD	72" 4kW HD or SuperHD	48" 12kW HD or SuperHD	72" 12kW HD or SuperHD
Dimensions	<ul style="list-style-type: none"> <li>• Pedestal: 412 mm x 402 mm (to top of antenna)</li> <li>• Antenna length: 1306 mm</li> </ul>	<ul style="list-style-type: none"> <li>• Pedestal: 412 mm x 402 mm (to top of antenna)</li> <li>• Antenna length: 1918 mm</li> </ul>	<ul style="list-style-type: none"> <li>• Pedestal: 412 mm x 402 mm (to top of antenna)</li> <li>• Antenna length: 1306 mm</li> </ul>	<ul style="list-style-type: none"> <li>• Pedestal: 412 mm x 402 mm (to top of antenna)</li> <li>• Antenna length: 1918 mm</li> </ul>
Weight	26 kg (with antenna)	29 kg (with antenna)	26 kg (with antenna)	29 kg (with antenna)
Supply voltage	10.8 to 32 volts (using VCM100)	10.8 to 32 volts (using VCM100)	10.8 to 32 volts (using VCM100)	10.8 to 32 volts (using VCM100)
Power consumption (typical)	< 70 watts	< 70 watts	< 110 watts	< 110 watts
Power consumption (standby)	< 30 watts	< 30 watts	< 30 watts	< 30 watts
Power consumption (sleep)	< 1.2 watts	< 1.2 watts	< 1.2 watts	< 1.2 watts
Maximum range scale	72 nautical miles	72 nautical miles	72 nautical miles	72 nautical miles

	48" 4kW HD or SuperHD	72" 4kW HD or SuperHD	48" 12kW HD or SuperHD	72" 12kW HD or SuperHD
Warm-up time	75 seconds	75 seconds	75 seconds	75 seconds
Standby to transmit	2.5 seconds	2.5 seconds	2.5 seconds	2.5 seconds
<b>Environmental:</b>				
Waterproof rating	IPX6	IPX6	IPX6	IPX6
Operating temperature range	-10°C to +55°C	-10°C to +55°C	-10°C to +55°C	-10°C to +55°C
Humidity	Up to 95% at 35°C	Up to 95% at 35°C	Up to 95% at 35°C	Up to 95% at 35°C
Maximum wind speed	85 knots	85 knots	85 knots	85 knots

### Range

Range (Nm)	Expanded range (Nm)	Pulse width (nominal)	PRF
0.125, 0.25	N/A	75 ns	3 kHz
0.5	N/A	100 ns	3 kHz
0.75	0.125, 0.25	150 ns	3 kHz
N/A	0.5	250 ns	3 kHz
1.5	0.75	350 ns	2 kHz
3	N/A	450 ns	1.5 kHz
N/A	1.5	600 ns	1.3 kHz
6 +	3 +	1.0 us	820 Hz

## Transmitter

	<b>48" 4kW HD or SuperHD</b>	<b>72" 4kW HD or SuperHD</b>	<b>48" 12kW HD or SuperHD</b>	<b>72" 12kW HD or SuperHD</b>
Transmitter frequency	9405 MHz $\pm$ 20 MHz	9405 MHz $\pm$ 20 MHz	9405 MHz $\pm$ 20 MHz	9405 MHz $\pm$ 20 MHz
Peak power output	4 kW	4 kW	12 kW	12 kW
Standby mode	Magnetron heater: ON Magnetron control: ON All other services: OFF	Magnetron heater: ON Magnetron control: ON All other services: OFF	Magnetron heater: ON Magnetron control: ON All other services: OFF	Magnetron heater: ON Magnetron control: ON All other services: OFF

## Receiver (all models)

Intermediate frequency:	70 MHz
Receiver characteristic:	Linear
Receiver noise:	Less than 5 dB (including low noise converter and IF amplifier)
Bandwidth:	Matched digital filter for each pulse length

## Antenna

	<b>48" 4kW HD or SuperHD</b>	<b>72" 4kW HD or SuperHD</b>	<b>48" 12kW HD or SuperHD</b>	<b>72" 12kW HD or SuperHD</b>
Beamwidth (vertical)	25° (nominal)	25° (nominal)	25° (nominal)	25° (nominal)
Beamwidth (horizontal)	1.85° (nominal)	1.15° (nominal)	1.85° (nominal)	1.15° (nominal)
Polarization	Horizontal	Horizontal	Horizontal	Horizontal
Rotation speed	24 RPM 48 RPM (compatible displays and scanners only)	24 RPM 48 RPM (compatible displays and scanners only)	24 RPM 48 RPM (compatible displays and scanners only)	24 RPM 48 RPM (compatible displays and scanners only)



SVIB

**Raymarine®**  
S-V-B

[www.raymarine.com](http://www.raymarine.com)

CE0191ⓘ