

Quick guide Mercury Mounting WiMEA Wireless kill switch

NOTE

Do not touch or cut any existing wires or electrically conducting components before you make sure the main voltage switch is OFF. Only set the main voltage switch to ON after you are finished cutting and connecting wires. Make sure that all wires and conductive connection points are free from corrosion before connecting any wires.

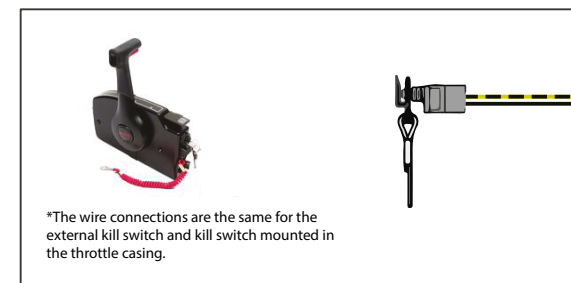
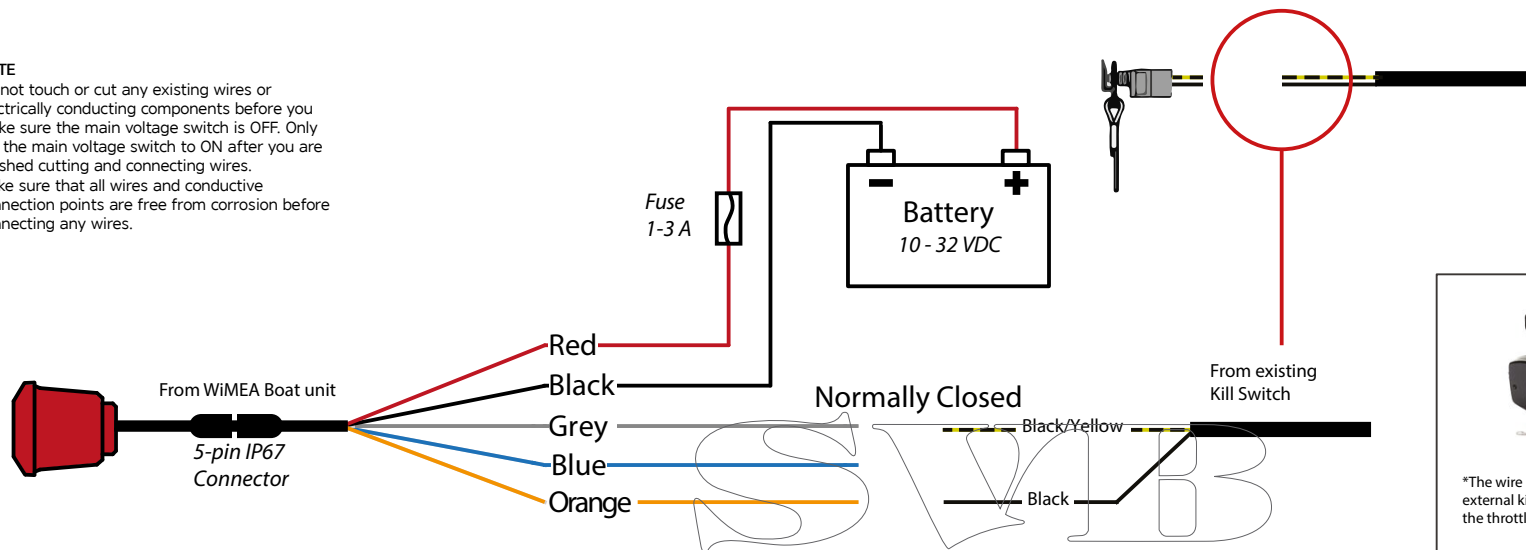

Connecting the Power

- (10-30 Vdc)
1. Use a test light or a voltmeter to determine the polarity of the voltage source.
 2. Connect the red (+ or positive) wire to the positive voltage terminal. (If you use the fuse block on the boat, route the positive connection through the fuse, as shown on the diagram.)
 3. Connect the black (- or ground) wire to the negative voltage terminal.
 4. Install or check the 1-3 A fuse (in the in-line fuse holder, or on the fuse block of the boat).
 5. Use wire hoods suitable for the wire dimension (20AWG, 0.75mm²) or connection point on the fuse block.

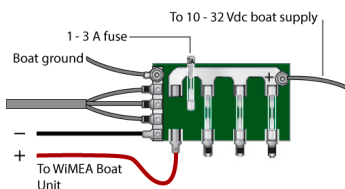

NOTE

Use an AGC / 3AG - 1-3 Amp replacement fuse. If it is necessary to extend the power and ground wires, use 20 AWG or thicker wire. You can wire the Power Wires directly to the main boat battery, or if your boat has an electrical system, you might be able to wire the Power Wires to an unused holder on the fuse block. If your boat has an NMEA or NMEA2000 system installed you can use this system as a power supply for the WiMEA Boat Unit, if enough power is available. Please make sure to check a relevant source for information on power availability in your NMEA system. NMEA website: www.nmea.org



NOTE

The maximum WiMEA Boat Unit input voltage is 32 Vdc. Do not exceed this voltage because this can damage the WiMEA Boat Unit and void the warranty.

Connecting Signal wires

Mercury uses «Normally Closed» kill switch principle as standard. This means that the engine kill switch shorts circuits to stop the engine. We recommend to verify this by simply trying to start the engine(s), whilst the existing kill switch signal wires are not connected. See page 36 in the usermanual for further instructions.

1. **Common - Grey - Always used when connecting the WiMEA Boat Unit Signal wires.**
2. **Normally Open (NO) - Blue - Used when your existing system is a Normally Open kill switch system.**
3. **Normally Closed (NC) - Orange - Used when your existing system is a Normally Closed kill switch system. This is the principle used by Mercury.**

Installing WiMEA in a metal boat

If your helm is made out of conducting materials the wireless signals from WiMEA may be degraded. The amount of signal degradation experienced may vary from across boats and must be tested for each case. If the signal is very poor you can install a separate external antenna outside of your helm to increase the signal strength. Please contact FELL support at www.fell.no/support for more information.

NOTE

Make sure that all wire connections are waterproof by using heat shrinkable butt splices or similar when connecting wires.

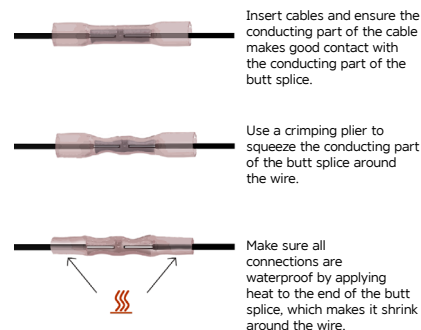

Multiple engine configurations

If you have several engines on your boat and your boat is already fitted with a kill switch you can connect the wires as described above to the two existing signal wires leading to the existing mechanical switch in your helm or throttle. You may notice that the existing wires consists of a splitter component on the wires. This splitter must not be removed, as this splitter translates the signal from the single mechanical kill switch into a kill switch signal for multiple engines. You should connect the WiMEA Boat Unit wires above this splitter, i.e. on the last two wires leading into the existing mechanical switch installed in your helm.

NOTE

If you have multiple engines and do not have an existing kill switch, wires and a splitter must be bought from your engine manufacturer or local retailer. Please contact your local engine retailer or manufacturer.

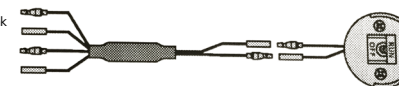

© FELL AS, Nedre Storgate 46, N-3015, Drammen, Norway, FELL, WiMEA®, WiMEAB®, WiMEAB® Protocol, WiMEAB® Protocol and its logos are trademarks of FELL AS, its subsidiaries and affiliates. The shape and design of this product are a trade dress of FELL AS, subsidiaries and affiliates. NMEA®, NMEA 2000®, and the NMEA 2000 logo are registered trademarks of the National Marine Electronics Association. All other trademarks or registered trademarks are the property of their respective owners. Designed in Norway. Made in China and Taiwan. All rights reserved. Product features, appearances and specifications may be subject to change without notice. Read all instructions carefully before use. Visit www.fell.no/support for complete Owner's Manual. Please retain this information for future reference.