



# OWNER'S MANUAL

## WhisperPower Power Module Genverter WP-PMG



### Inverter and engine controller for PM Generator 230/120V



- Excellent choice to replace traditional gensets
- 6kW continuous 230V power from your variable speed generator system
- Suitable for GV/Piccolo 4,5 and 8
- Also available in 120V/60 Hz model (4kW)
- High efficiency and strong peak power
- Outstanding voltage stability
- Saving fuel and ensuring smooth running of your genset
- Genverter Power, the best choice for your energy supply

#### 1. INTRODUCTION

Thanks for choosing our product. The Power Module for Genverter (WP-PMG) is an essential link between your WhisperPower Genverter and your AC electrical system.

It contains both an engine control module and a 230VAC pure sine wave inverter, and it acts as a user interface to your Piccolo genverter system. WhisperPower Genverters are state-of-the-art generators using very compact and highly efficient Permanent Magnet alternators to produce electric power. Unlike traditional fixed speed generator sets, however, Genverters may produce output voltages up to 440VAC with frequencies as high as 400Hz. From this, the WP-PMG produces a stable sinusoidal AC voltage at 50Hz or 60Hz, as required by regular 230V or 120V appliances. Safety is enhanced by WP-PMG's capability to blow fuses when a short-circuit occurs.

#### Use of this manual

This manual serves as a guideline for safe and effective installation, as well as correct operation, maintenance and, if necessary, troubleshooting of the WP-PMG unit. It is recommended to keep the manual in good condition for future use. It should be kept in a dry and clean place, and available any time.

#### General precautions

To ensure safe and sustainable operation of the unit, the handling and safety instructions detailed in this manual shall be followed at all times. Every person working on or with the unit should be familiar with the contents of this document. Also bear in mind that all applicable (safety) standards and (local) regulations shall be followed at all times. Furthermore, only qualified and authorized technical experts are permitted to perform maintenance activities which require opening the system.

#### IMPORTANT!

Throughout this manual, the following alert symbol is used to indicate potential hazard:



#### CAUTION / WARNING!

*Risk of equipment damage or personal injury. Always be aware that your actions may have an impact on safety and/or on product performance. Carefully follow instructions documented.*

#### 2. INSTRUCTIONS FOR USE

#### CAUTION ! Risk of fire, electric shock and/or equipment damage

- This unit was designed for dry and clean environments.
- Do not expose it to dust, rain, snow or liquids of any type.
- Do not smoke near the WP-PMG.
- To prevent overheating, DO NOT block ventilation.
- Do not place any inflammable materials near the unit.
- Verify the condition and connection of all cables on a regular basis.

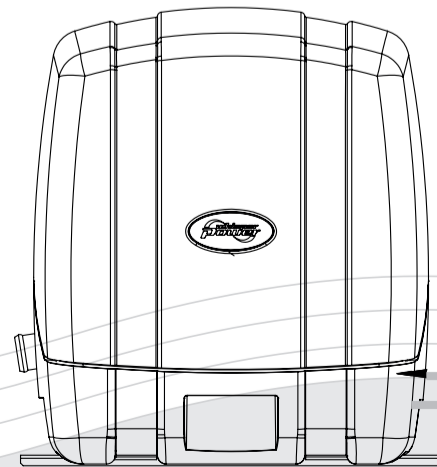

**NEVER** connect the WP-PMG directly to the grid. Without a transfer switch, the unit will be damaged beyond repair.

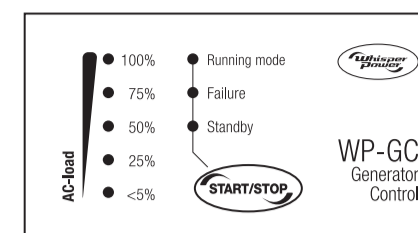
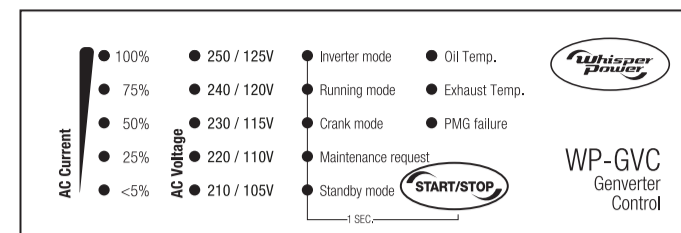

(Optional)

#### Monitoring and Control

This section describes the panel on the WP-PMG. The standard remote control panel provides almost the same monitoring and control options. The optional small-size panel provides only basic information and control.

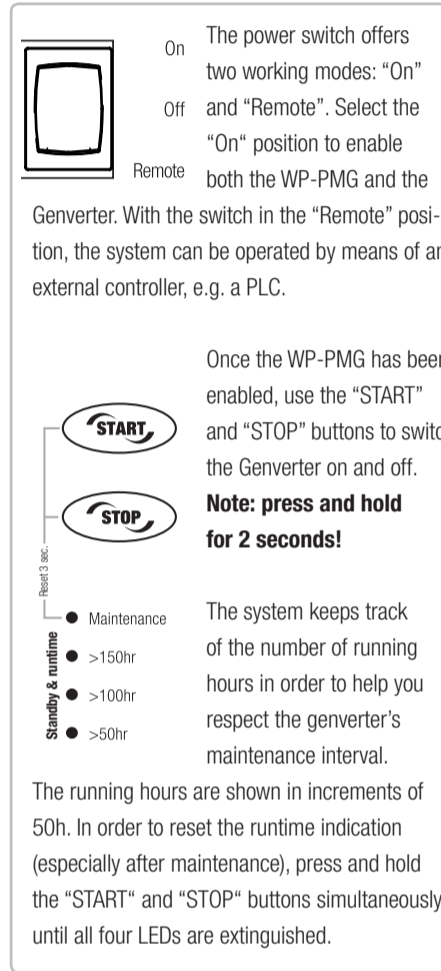

When the Genverter is started, the control panel LEDs will provide various types of operating information:

CONTROL PANEL INFORMATION	
<ul style="list-style-type: none"> <li>● 100%</li> <li>● 75%</li> <li>● 50%</li> <li>● 25%</li> <li>● &lt;5%</li> </ul>	<p>A series of five LEDs shows the unit's output as a percentage of its rated output. If all five LEDs start blinking, the unit is overloaded and may shut down at any moment.</p> <p>During genverter start-up, the lower four LEDs light up three times (1, 2, 3, 4s) when the start procedure is initialized, when fuel is being supplied and when the engine is being cranked.</p>
<ul style="list-style-type: none"> <li>● 250 / 125V</li> <li>● 240 / 120V</li> <li>● 230 / 115V</li> <li>● 220 / 110V Fuel</li> <li>● 210 / 105V Crank</li> </ul>	<p>A series of five LEDs shows the unit's approximate output voltage. In a range from 210V to 250V, the 220V or 230V LED will typically light up. For 120V model, the 115V or 120V LED will typically light up.</p> <p>During genverter start-up, the lower two LEDs light up while fuel is being supplied and while the engine is being cranked, as applicable.</p>
<ul style="list-style-type: none"> <li>● Inv failure</li> <li>● Oil press</li> <li>● Oil temp</li> <li>● Exh temp</li> </ul>	<p>A series of four LEDs alerting in case of:</p> <ul style="list-style-type: none"> <li>- inverter failure</li> <li>- high oil pressure</li> <li>- high oil temperature</li> <li>- high exhaust temperature</li> </ul> <p>Refer to the Troubleshooting section.</p>

#### 3. TROUBLESHOOTING

The table below lists possible failure conditions. If the failure LED illuminates, switch off the WP-PMG, adopt the applicable solution(s) and switch the WP-PMG on again.

PROBLEM	POSSIBLE CAUSE	SOLUTION
Inverter failure LED illuminated	Ambient temperature is too high	Move the WP-PMG to a colder position, or reduce the load
	Ventilation is blocked	Improve ventilation
	AC input is out of range	Check generator output voltage and frequency, and correct if necessary
Oil pressure LED illuminated	Oil leakage	Contact WhisperPower Service centre
	Oil level too low	Refill
Oil temperature LED illuminated	Insufficient cooling	Check coolant pump; replace impeller and/or gasket if necessary
Exhaust temperature LED illuminated	Load too high	Reduce load
	Too rich fuel	Contact WhisperPower Service centre
The unit does not respond at all. All LEDs are off.	Power switch in "Off" position.	Choose either "On" or "Remote".
	Fuse blown	Follow the instructions given in "Engine Control Unit: replacing the fuse".

#### ENGINE CONTROL UNIT: REPLACING THE FUSE

In the unlikely event that the green 30A blade fuse (order no. 50212175) is blown, proceed as follows.

1. Disable the unit (power switch in "Off" position).
2. Remove the cover protecting the terminals.
3. Remove any control cables passing through the upper cover (containing the local control panel).
4. Unscrew the four tapping screws that retain the upper cover.
5. Trying not to disconnect the local control panel cable, gently lift up the cover in order to gain access to the fuse.
6. Replace the fuse.
7. If necessary, reconnect the local control panel.
8. Gently move the cover back into place and fasten it using the four tapping screws.
9. Carefully reconnect the cables removed in step 3.
10. Put the cover protecting the terminals back into place and tighten the tapping screws.
11. Re-enable the unit and check its correct operation.

#### 4. INSTALLATION

##### General Remarks

Local and/or special regulations may apply depending on the type of installation involved. It is essential that each and every circuit in the electrical system is properly installed by a qualified electrician using all applicable standards.

##### CAUTION !

**Risk of electric shock, personal injury, explosion and/or equipment damage**



- Do not work on the WP-PMG or the electrical installation while it is still connected to a power source.
- Never connect the inverter output to a 230V connection of the public grid.
- All electrical safety/shutdown and circuit breaking systems have to be installed separate from the WP-PMG.

In Europe, pleasure craft smaller than 24 meter is subject to the EC Recreational Craft Directive, which refers to EN ISO 13297:2012 (Small craft - Electrical systems - Alternating current installations).

When installing a 230V or 120V system on a vehicle, be aware that people are not used to having such systems on a vehicle. Put warning signs on wall sockets and on junction boxes. Instruct non-regular users of the vehicle. Warn maintenance personnel of garages servicing the vehicle.

##### Grounding & Neutral Bonding

The housings of the Genverter and of the WP-PMG are grounded by means of the green/yellow wires in the Genverter and output cables. In the WP-PMG, "neutral" and "ground" are interconnected by means of a neutral bonding wire. In the case of a free-floating system, it is possible to remove the bonding wire. This should only be done by experts when installing such a system. For vehicles, methods of protection are subject to rules that may vary depending on the use of the vehicle and local standards. Experts in this field should be consulted.

##### Transfer Switching

When a connection to the public grid is required, a power source selector must be installed between the WP-PMG and the vessel's / vehicle's electrical system. This so-called transfer switch is an essential safety device allowing all AC consumers to be switched off simultaneously and separating the WP-PMG output from the grid. WhisperPower recommends the installation of a WP AC Transfer System Switch. By default, this uses grid input. When it detects WP-PMG input, it automatically switches over to generator input after 10 seconds delay time. Even more advanced, a WP WhisperSwitch allows simultaneous input from the Genverter and the grid. Refer to the applicable product instructions.

##### Location

When looking for a proper position for installing the WP-PMG, all relevant aspects have to be taken into account, in particular:

- The unit must be installed in a dry and clean place protected from strong vibrations. Do not expose the unit to dust, rain, snow or liquids of any type. The input being three-phase alternating current, the unit can be installed at some distance from the Genverter.
- Ensure that ventilation airflow is not obstructed in any way. Keep a free space of 200mm around the unit.
- The unit's control panel must remain accessible.
- The unit contains components capable of producing arcs or sparks. To prevent fire or explosion, do not install the unit in compartments containing batteries or flammable materials or in locations requiring ignition protected equipment. Moreover, gases from batteries will corrode and damage the unit.

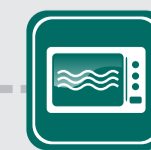
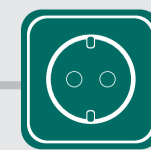

**List of Materials**

The delivery includes the WP-PMG and a WhisperPower remote control panel with its 10 meter RJ12 connecting cable. 5 meter and 15 meter cables are available on request.

- Additional materials required:
- Screws / bolts (4 x Ø 6mm, with plugs if necessary) to mount the unit to a wall.
  - A sufficient number cable clamps suitable for short-circuit installations.
  - Cable lugs (7) for connecting the various 6mm<sup>2</sup> wires.
  - Cable ties, for securing the input and output cables (at least 4, e.g. 140mm x 3.5mm).
  - An output cable, i.e. any cable of appropriate rating and length to accommodate the application.
  - A slow-reacting output fuse (32A recommended).
  - A grounding cable of sufficient length, fitted with suitable lugs.
  - If another 230V source may be available, a transfer switch.

**STEP 1: Mounting the unit**

- Determine the bolt / screw positions.
- Turn the screws / bolts (Ø 6mm) into the wall but do not tighten them entirely.
- Place the housing over the screws / bolts.
- Fix the housing by fastening the screws securely.
- Install the grounding cable between the ground stud (marked  $\perp$ ) and the vessel's/vehicle's ground connection.



**STEP 2: Connecting the input cable**

The genverter cable (e.g. 4 x 6mm<sup>2</sup>) shall be installed short-circuit proof using adequate clamps.

Remove the cover protecting the terminals by unscrewing the two tapping screws. Provide the Genverter cable wires with lugs. Connect the green/yellow wire to the PE terminal (input section) and connect the three live wires to the L1, L2 and L3 input terminals.

Use cable ties of sufficient strength as a strain relief.

**STEP 3: Connecting the output cable**

A slow-reacting fuse (32A recommended) should be installed to protect the installed electrical system. Make sure there is a Residual Current Device between the unit and any on board AC equipment.

Provide the output cable wires with lugs and connect the wires to the output terminals as follows: green/yellow to PE, brown to L1, blue to N.

Use cable ties of sufficient strength as a strain relief.

**STEP 4: Connecting the engine control cable**

Insert the plug of the engine control cable into its socket.

**Note:** For connection to a 2 cylinder generator, external hardware is required for operating the fuel valve and the glow plugs.

**STEP 5: Connecting the remote control panels (optional)**

The WP-PMG has a local control panel, which is on the unit, and a remote control panel, the installation of which is optional. An optional small-size remote control is also available.

The remote control panels can be mounted either on or in the dashboard. When a remote control is mounted on the dashboard, the back cover can be used as a drill template.

The connecting cable can exit in any direction through one of pre-shaped ports in the sides of the plastic case or through a hole in the dashboard. On the WP-PMG, the cable is plugged into a PMG REMOTE port. Similarly, a second remote panel can be connected to the other PMG REMOTE port.

**STEP 6: Reattaching the cover**

Put the cover protecting the terminals back into place and tighten the tapping screws.

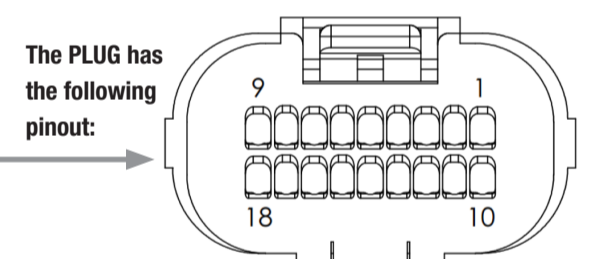
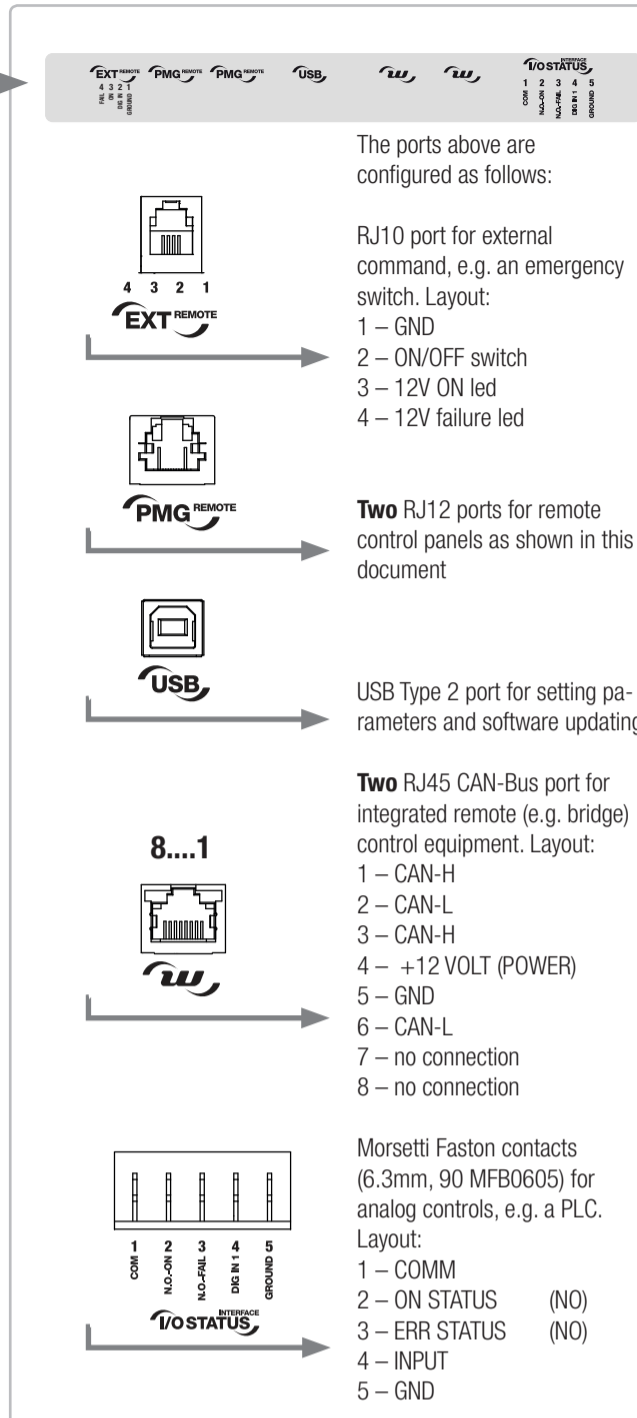
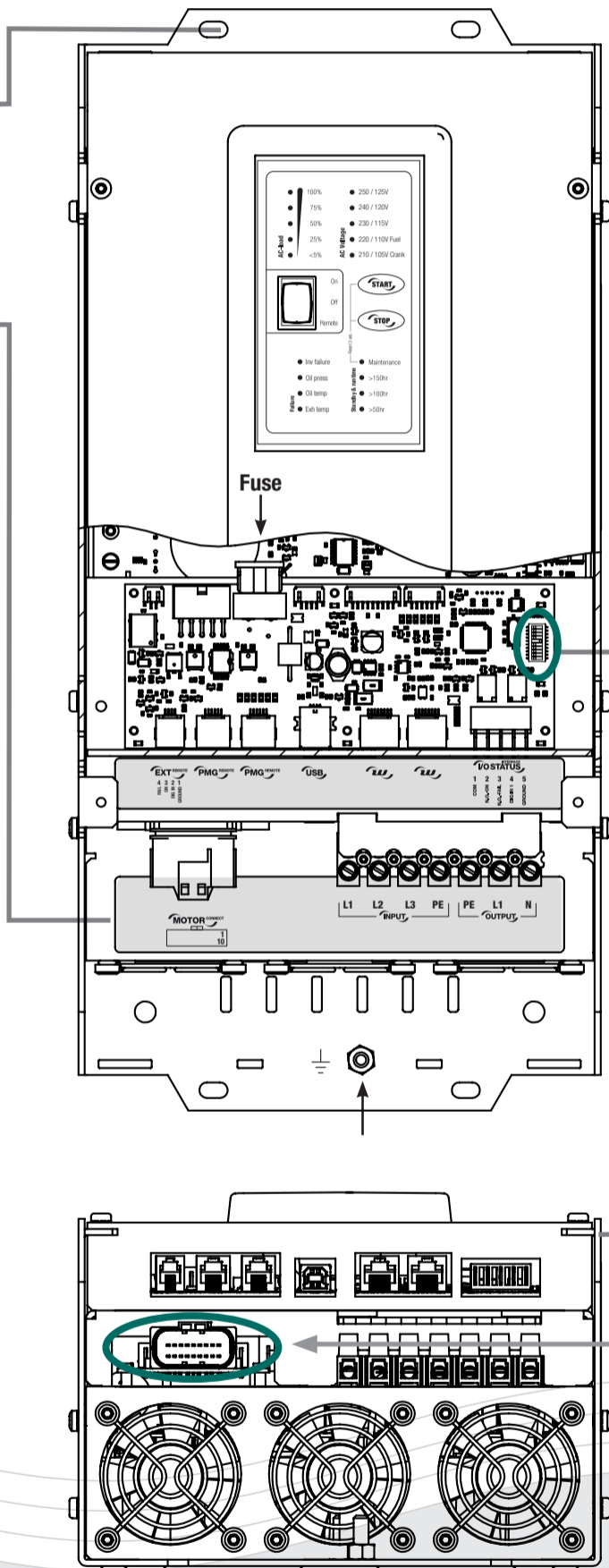

PIN	SIGNAL	DESCRIPTION
1	Engine_start	Start Engine Out
2	Engine_start	Start Engine Out
3	+Vbat	Battery +12V
4	+Vbat	Battery +12V
5	Gnd	Battery Ground
6	Step_d	Stepper Phase "D" Out
7	Step_c	Stepper Phase "C" Out
8	Step_b	Stepper Phase "B" Out
9	Step_a	Stepper Phase "A" Out
10	Engine_start	Start Engine Out
11	Fuel_pump	Fuel Pump Out
12	Fuel_valve	Fuel Valve Out
13	+Vbat	Battery +12V
14	Gnd	Battery Ground
15	P_oil	Oil Pressure In
16	P_oil_aux	Oil Pressure In Aux.
17	P_oil	Oil Temperature In
18	T_exhaust	Exhaust Temperature In

Article nr.	POWER MODULE FOR GENVERTER 6KW -230V	POWER MODULE FOR GENVERTER 3.5KW -120V
	60201405	60201415
<b>GENERAL SPECIFICATIONS</b>		
Genverter model	Genverter 5 or 8 Piccolo	Genverter 4 or Piccolo 5
Output load	True sine	True sine
Output voltage	200 .. 240 VAC (nominal 230V)	105 .. 125 VAC (nominal 120V)
Output voltage stability	+/- 5% (resistive load step 0 .. 100%)	+/- 5% (resistive load step 0 .. 100%)
Output frequency	45 .. 55 Hz (nominal 50Hz)	55 .. 65 Hz (nominal 60Hz)
Frequency variations	< 1%	< 1%
Output current	28A	30A
Nominal power	6kVA	3,5kVA
Continuous power (cos phi = 1)	6kW	3,5kW
Nominal efficiency (@ full load)	95%	95%
Peak efficiency	97%	97%
Input voltage	3 times 220 .. 440VAC	3 times 220 .. 440VAC
Input frequency	200 .. 400Hz	200 .. 400Hz
Max. input current	22A	15A
Weight	7,6kg	7,6kg
Dimensions (h x w x d)	436 x 196 x 148mm	436 x 196 x 148mm
Mounting rectangle (h x w)	420 x 100mm	420 x 100mm
<b>TECHNICAL SPECIFICATIONS</b>		
Voltage THD (Total Harmonic Distortion)	< 5%	< 5%
Short circuit protection	yes	yes
Mean time between failure	10 years	10 years
Lifetime expectancy (@ 40°C and nominal load)	100,000 hours	100,000 hours
Local read out module: Inverter status load bar, voltage and runtime indicator (for maintenance purposes) and failure notification		
Remote panel (LED)	Inverter status load bar, voltage indicator, AC input present and failure notification	
USB	For software parameter configuration	
Potential-free status contact	Inverter enabled / disabled	
Wire system	L1 - N - PE	
Recommended cable cross input / protection fuse	4mm <sup>2</sup> / 32A	
Recommended cable cross output / protection fuse	4mm <sup>2</sup> / 32A RCD	
Remote panel connection	RJ12 twisted cable (max. 15m)	
Engine interface connection	Engine RPM request (pwm signal; optimal)	
<b>CONDITIONS</b>		
Operating temperature	-20 .. 70°C (linear derating above 40°C)	
Storage temperature	-40 .. 80°C	
Relative humidity in operation/storage	Max. 95% non-condensing	
Protection degree	IP23	
Ventilation	Forced cooling	
<b>COMPLIANCE</b>		
Directives: EMC 2004/108/EC, LVD 2006/95/EC		
Standards: EN 55022 (emission), EN 61000-3-2 (harmonics), EN 61000-4-11, EN 61000-6-1, EN 61000-6-1 (immunity), EN 60945 (maritime navigation and radiocommunication), EN 60950 (safety)		

**ADVANCED FEATURES**

The dipswitches allow a number of advanced settings to be made. On a 230V/50Hz unit, the default setting for all switches is OFF. Voltage optimization is possible using the VAC OUT switches and may save fuel, especially in case of high resistive loads (lighting, heating). High inductive loads such as aircons, on the other hand, may be handled more easily when the unit is set at 90% or even 80% of its rated output.

**230V MODEL**

- DIP SWITCHES 1-10**
- VAC OUT [volt] 110%
  - VAC OUT [volt] 95%
  - VAC OUT [volt] 90%
  - 60 Hz (default OFF= 50 Hz)
  - PAC OUT 5.4kVA (default OFF= 6kVA)
  - PAC OUT 4.8kVA (default OFF= 6kVA)
  - Reverse fuel valve (default ON)
  - Cold start mode on (default OFF)
  - Not available
  - Not available

**120V MODEL**

- DIP SWITCHES 1-10**
- VAC OUT [volt] 110%
  - VAC OUT [volt] 95%
  - VAC OUT [volt] 90%
  - 60 Hz (default ON)
  - PAC OUT 3.2kVA (default OFF= 3.5kVA)
  - PAC OUT 2.8kVA (default OFF= 3.5kVA)
  - Reverse fuel valve (default ON)
  - Cold start mode on (default OFF)
  - Not available
  - Not available

**6. WARRANTY TERMS AND CONDITIONS**

WhisperPower guarantees that the equipment has been built according to the legally applicable standards and specifications. WhisperPower assures the product warranty of the Power Module for Genverter during two years after purchase, on the condition that all instructions and warnings given in this manual are taken into account during installation and operation. The warranty is limited to the costs of repair and/or replacement of the product by WhisperPower only. Costs for installation labor or shipping of the defective parts are not covered by this warranty.

**7. CE MANUFACTURER'S DECLARATION**

We, WhisperPower BV, Kelvinlaan 82, 9207 JB Drachten, Netherlands, hereby declare that:  
 Product: 60201405 and 60201415  
 WhisperPower-Power Module Genverter  
 Is in conformity with the following provisions of the EC: 2004/108/EC (EMC Directive), the following harmonized standards having been applied:  
 - EN 55022:2010 (Information technology equipment - Radio disturbance characteristics - Limits and methods of measurement)  
 - EN 61000-3-2:2006 (Electromagnetic compatibility [EMC] Part 3-2: Limits - Limits for harmonic current emissions)  
 - EN 61000-6-1: 2007 (Electromagnetic compatibility [EMC], Generic standards. Immunity for residential, commercial and light-industrial environments)  
 - EN 60945:2002 (Maritime navigation and radiocommunication equipment and systems)  
 2006/95/EC (Low Voltage Directive), the following harmonized standard having been applied:  
 - EN 60950: 2000 (Safety of information technology equipment)

Drachten,  
 M. Favot, C.T.O. WhisperPower B.V.

